

# Mist Eliminator™ Spray Containment Dome For the AQUA-LATOR® High Speed Surface Aerator

## Spray Containment Dome

The Mist Eliminator™ spray containment dome is an optional accessory for the Aqua-Lator® high speed surface aerators. The dome controls the water flow from the powerful pumping action of the aerator at its discharge, redirecting it into the bulk liquid, thus minimizing mist and spray.

The Mist Eliminator™ dome can also be used where cold weather might otherwise restrict the use of floating aerators. The dome acts to retain heat and enables the aerators to continue operating during periods of extreme low temperatures.

The Mist Eliminator™ domes shown below are located at a municipal wastewater treatment plant in the northeast United States. Under windy conditions, the plant would receive complaints of drifting spray and odors from nearby residents. With the addition of the Mist Eliminator™ spray containment domes, complaints have ceased and the plant continues to meet operational requirements.



*Mist Eliminator™ spray containment domes installed at municipal wastewater treatment plant*

## Features

The Mist Eliminator™ dome can also be used in installations where cold weather conditions might otherwise restrict the use of floating aerators. The domed cover acts to retain heat and enable the aerators to continue operating during periods of lower temperatures.

- In cold weather conditions spray containment to minimize misting
- Fits all sizes of Aqua-Lator® aerators
- Durable, rugged construction
- Stainless steel mooring ears
- Protective coating
- Installs easily
- Minimal maintenance

## Operation

- Wastewater is pumped into and through the volute.
- As wastewater enters and then exits the discharge cone it breaks up into many small particles, creating an enlarged surface area for oxygen transfer.
- The spray discharge is contained within the inside of the Mist Eliminator™ dome, minimizing mist and better retaining the heat of the wastewater.
- Mixing and dispersion of the oxygen-enriched liquid occurs.

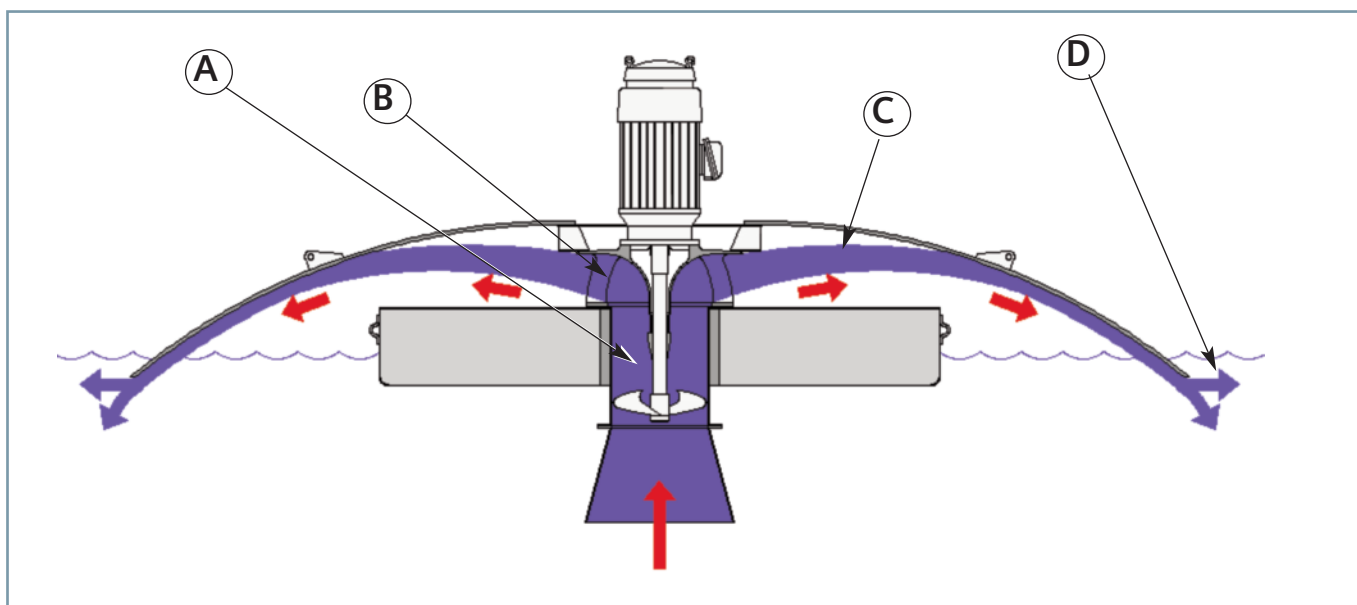

Siemens  
Water Technologies  
815.623.2111 phone  
815.623.6416 fax

© 2009 Siemens Water Technologies Corp.  
AP-MEdr-DS-0309  
Subject to change without prior notice.

Aqua-Lator and Mist Eliminator are trademarks of Siemens, its subsidiaries or affiliates

The information provided in this literature contains merely general descriptions or characteristics of performance which in actual case of use do not always apply as described or which may change as a result of further development of the products. An obligation to provide the respective characteristics shall only exist if expressly agreed in the terms of the contract.