

Manure & Biosolids Dewatering and Drying *Option with heat exchanger*

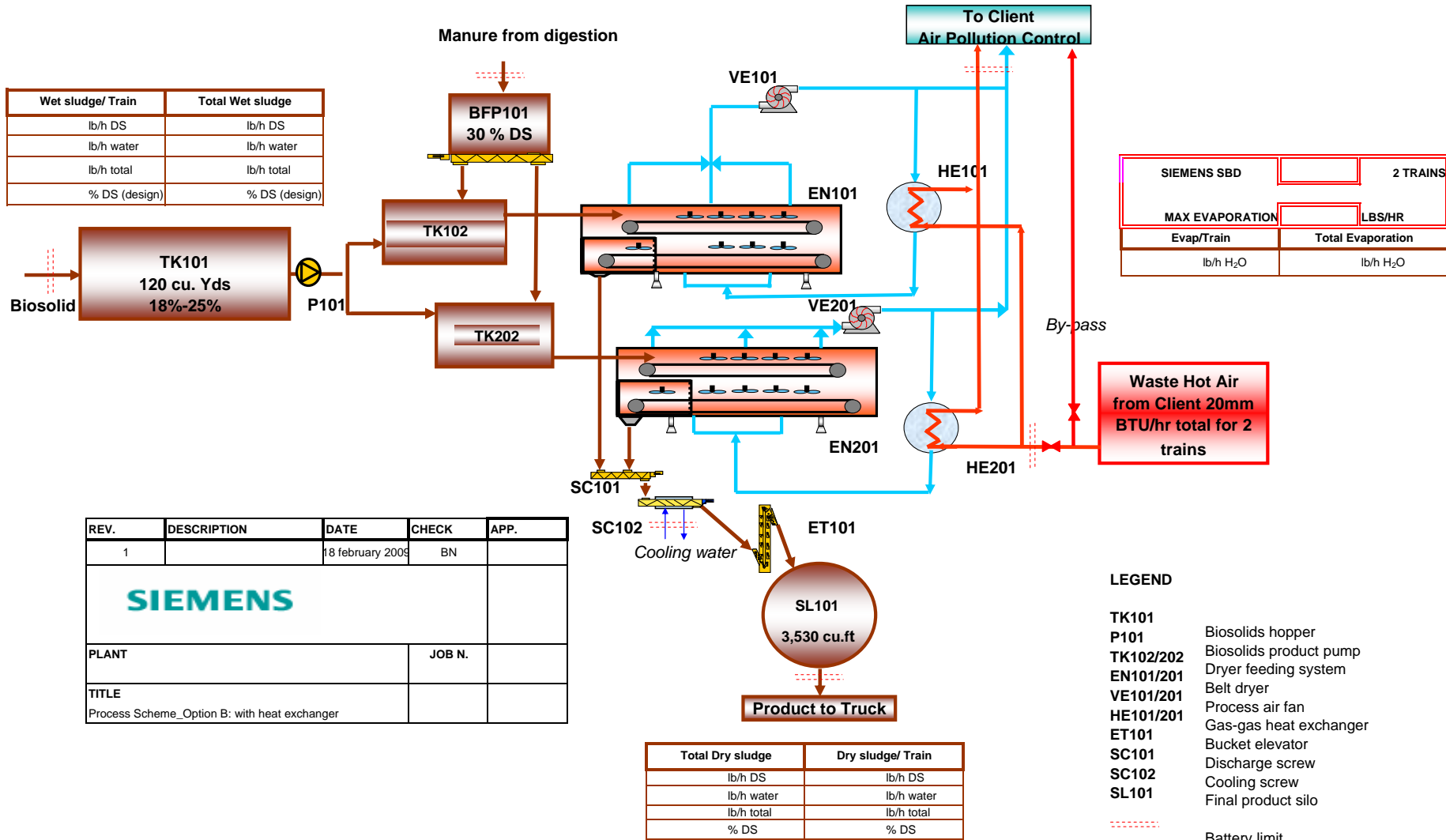

Wet sludge/ Train	Total Wet sludge
lb/h DS	lb/h DS
lb/h water	lb/h water
lb/h total	lb/h total
% DS (design)	% DS (design)

SIEMENS SBD	2 TRAINS
MAX EVAPORATION	LBS/HR
Evap/Train	Total Evaporation
lb/h H ₂ O	lb/h H ₂ O

REV.	DESCRIPTION	DATE	CHECK	APP.
1		18 february 2009	BN	
SIEMENS				
PLANT			JOB N.	
TITLE Process Scheme_Option B: with heat exchanger				

Total Dry sludge	Dry sludge/ Train
lb/h DS	lb/h DS
lb/h water	lb/h water
lb/h total	lb/h total
% DS	% DS

- LEGEND**
- TK101 Biosolids hopper
 - P101 Biosolids product pump
 - TK102/202 Dryer feeding system
 - EN101/201 Belt dryer
 - VE101/201 Process air fan
 - HE101/201 Gas-gas heat exchanger
 - ET101 Bucket elevator
 - SC101 Discharge screw
 - SC102 Cooling screw
 - SL101 Final product silo
- Battery limit