

Granador Juice installs AGAR® Moving Bed Bioreactor

Granador, a premium brand of Unidrink AG, is a well known beverage producer, located in Hitzkirch, Switzerland. Granador produces about 45 million bottles per year with distribution throughout Europe. The facility previously used an anaerobic reactor for wastewater treatment; however was not able to meet the discharge requirements for the sewer system.

Challenge

It was found that the wastewater quantity and composition varied widely due to the type of products processed in the manufacturing plant. With the widely varying production levels, the wastewater treatment solution needed to comply with the requirements without operational complexity. It was also important to have a simple, reliable, low maintenance solution.

Solution

To meet all of the project challenges, the AGAR® Moving Bed Bioreactor (MBBR) with a 1.3 hours retention time was the only solution. This innovative fixed-film moving bed process uses thousands of special suspended biomass carriers designed to create a large total surface area for biofilm growth – enhancing the biological wastewater treatment process without increasing the plant footprint. The AGAR® MBBR is ideal for handling the organic loads in food industry wastewater.

Manufacturing Facility at Granador Juice



Granador Juice installs AGAR® Moving Bed Bioreactor

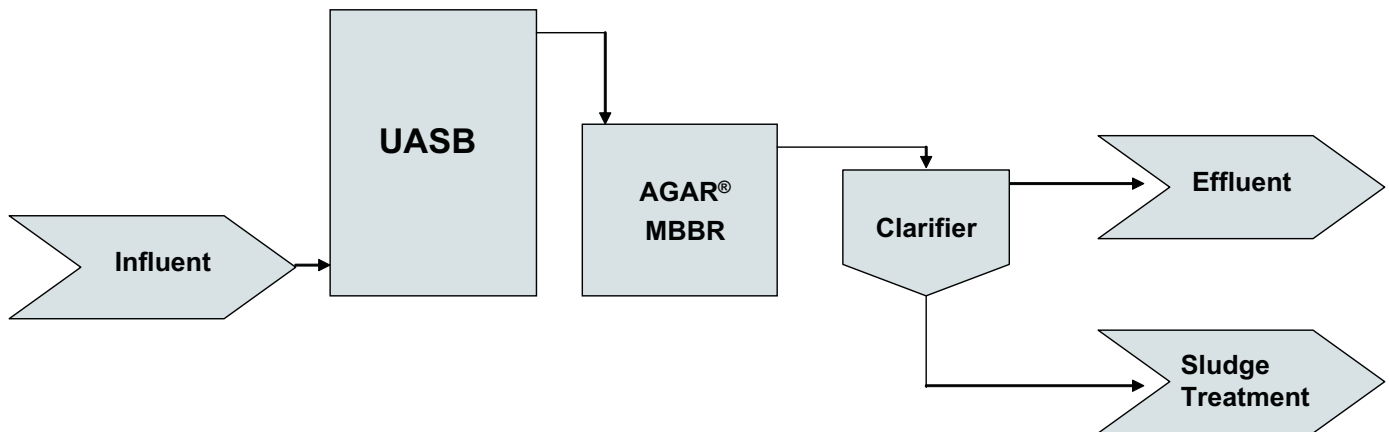

The wastewater treatment plant was designed with a typical COD concentration of 1000 mg/l flow to an anaerobic reactor, where about 70% of the COD is removed. The effluent from the anaerobic reactor passes through a single stage AGAR® MBBR for aerobic polishing. The system is filled to 54% with biomass carriers and operates as a roughing filter, in which the attached growth of bio-film on carriers is responsible for the removal of BOD, with no circulation of activated sludge.

The biomass carriers are mixed in the tank by unique airlift hydraulics, using the process air supplied through coarse bubble diffusers. Wedge wire screens are installed at the outlet of the AGAR® MBBR to retain the media inside the reactor. The flow of water, air bubbles and media scour the screens continuously to keep them clean.

Results

Despite the seasonal variation in wastewater composition the plant achieves higher efficiencies than required. The plant has been operating since July 2004 and consistently meets effluent requirements.

Biomass Carriers

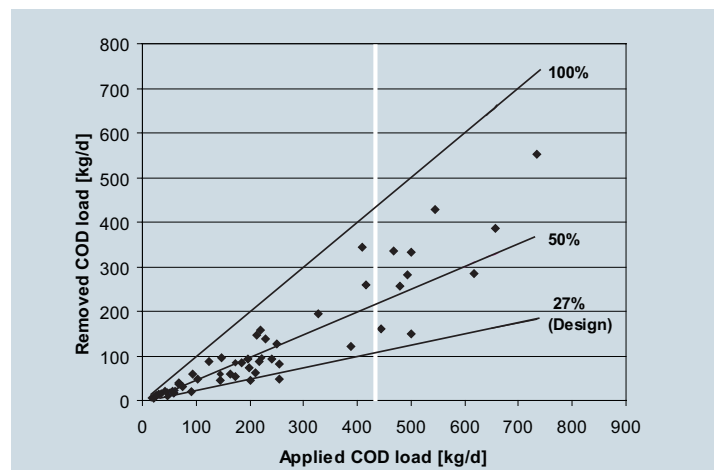

Siemens
Water Technologies
1051 Blake
Edwardsville, KS 66111
913-422-7600 phone
913-422-7667 fax

© 2007 Siemens Water Technologies Corp.
All rights reserved
BC-GJdr-CS-0807
Subject to change without prior notice.

AGAR is a trademark of AqWise-Wise Water Technoloiges, Ltd.

The information provided in this literature contains merely general descriptions or characteristics of performance which in actual case of use do not always apply as described or which may change as a result of further development of the products. An obligation to provide the respective characteristics shall only exist if expressly agreed in the terms of the contract.