

- NOTES:
1. ALL DIMENSIONS ARE IN INCHES (mm). ALL TOLERANCES ARE  $\pm .12"$  (3mm).
  2. ALL CONDUIT TO BE PLASTIC FLEX.
  3. ALL WEIGHTS ASSOCIATED WITH GENERAL ARRANGEMENT DRAWINGS ARE NOMINAL.
  4. ALL MOUNTING HARDWARE TO STAINLESS STEEL.
  5. ALL INSTRUMENTATION, TIMERS, ETC. SHOULD BE CHECKED FOR PROPER SETUP AND/OR CALIBRATION.
  6. TAGS ARE SIEMENS STANDARD LAMICOID WITH WHITE BACKGROUND AND BLACK TEXT. HUNG WITH PLASTIC TIE WRAPS.
  7. UNIT TO BE LEAK TESTED @ 100 PSIG.

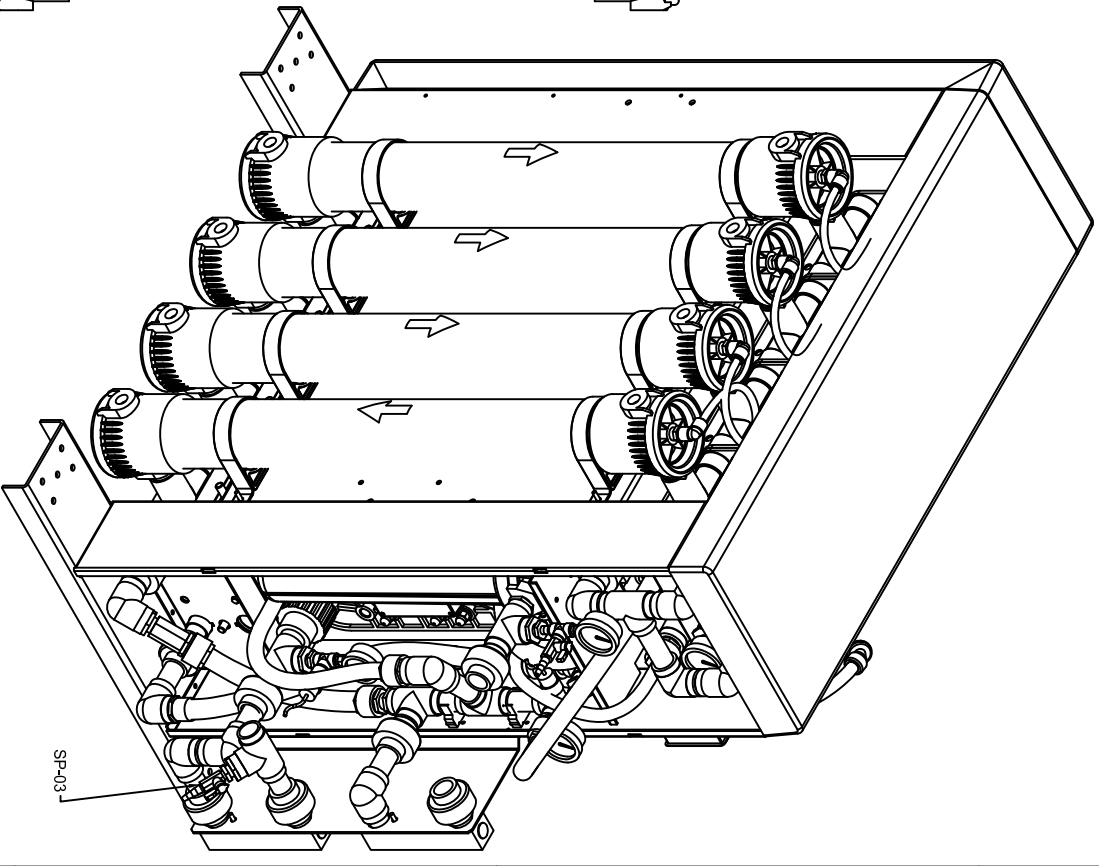
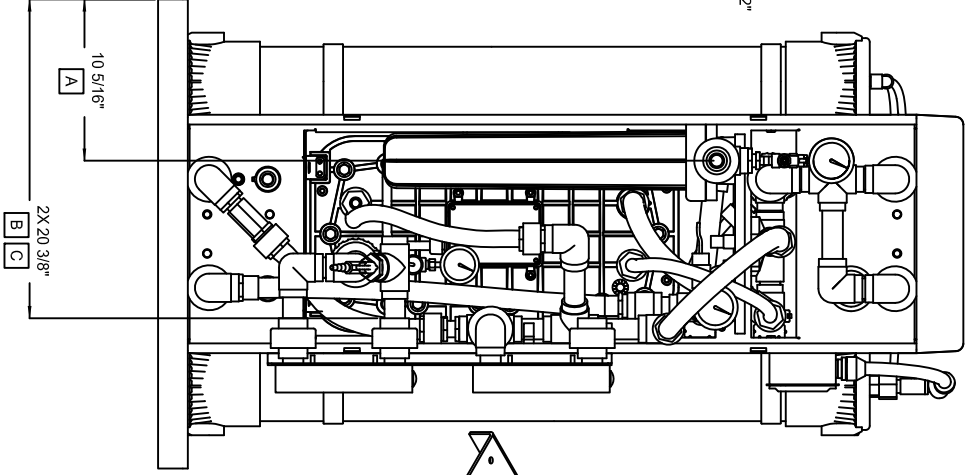
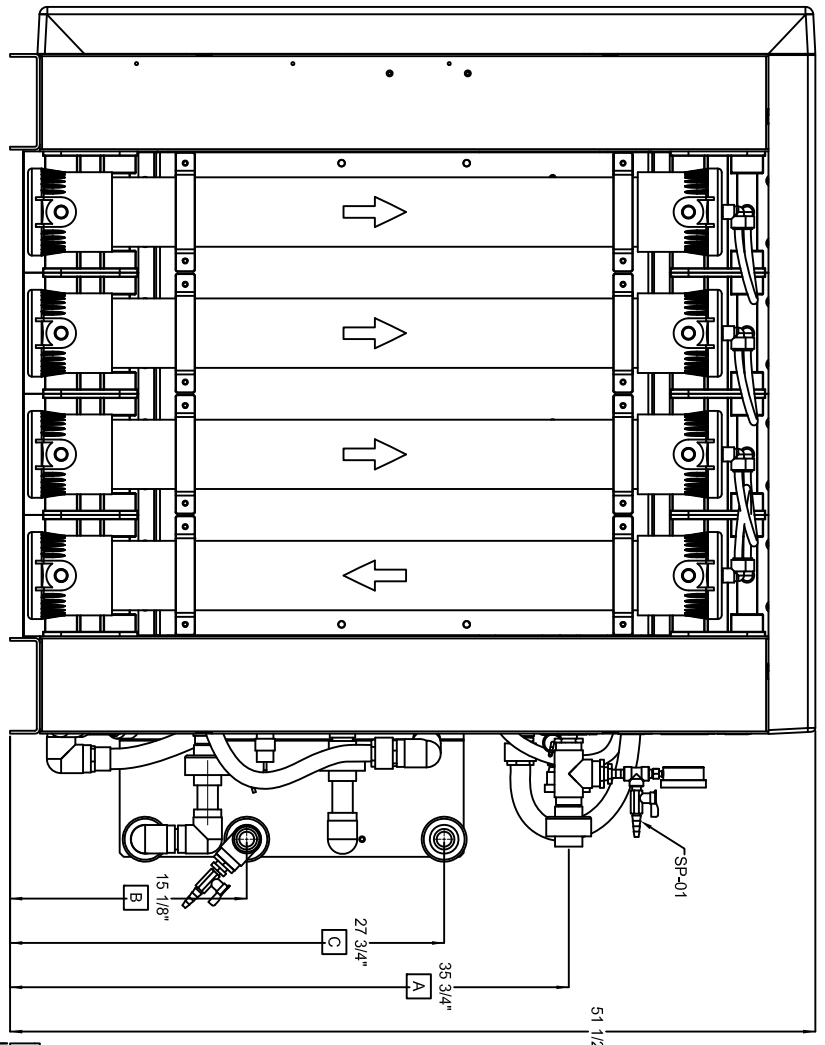
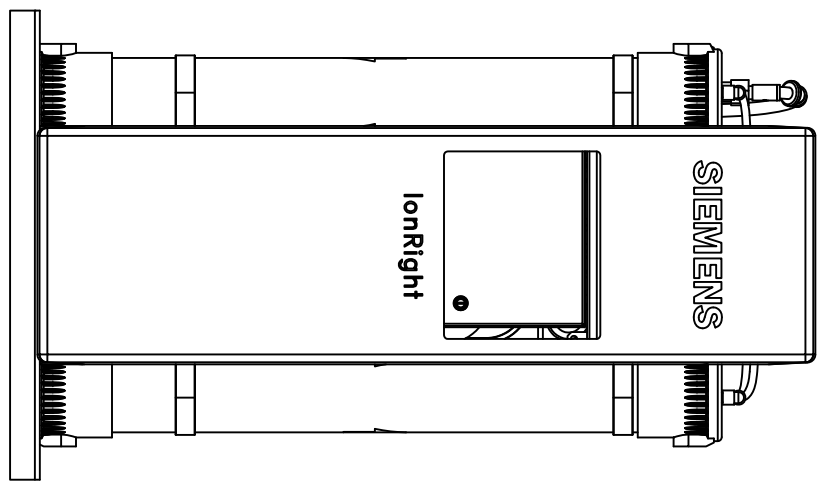
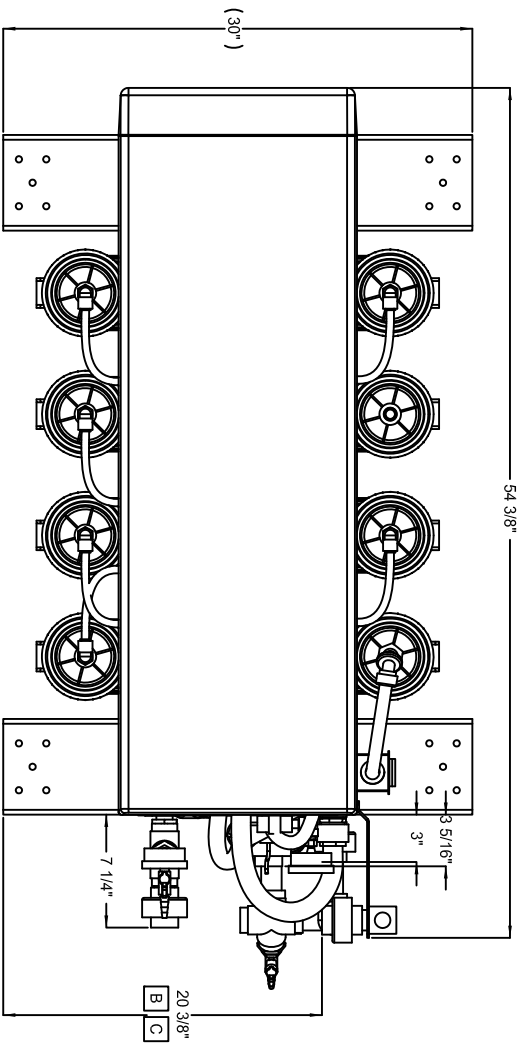

SYSTEM CONNECTIONS	
FLAG	INLET/OUTLET SPECIFICATION
A	1" SOC UNION FEED CONNECTION
B	1" SOC UNION PRODUCT CONNECTION
C	1" SOC UNION DRAIN CONNECTION

GENERAL ARRANGEMENT SPECIFICATIONS	
SKID LENGTH	54 3/8"
SKID WIDTH	30"
SKID HEIGHT	52"
WEIGHT DRY	600 LBS
WEIGHT WET (OPERATING)	820 LBS

STG: BORDER-0106-22X34D	INTL REF:INTR REF NO	PRINT NOT TO SCALE	REV	DESCRIPTION	DATE	DESIGN	CHKD	APPD	ECN
			4	SEE EGM DATABASE	01-16-10	MIS	CHD		

COMPANY CONFIDENTIAL

THIS DOCUMENT AND ALL INFORMATION CONTAINED HEREIN ARE THE PROPERTY OF SIEMENS ENERGY AND ITS AFFILIATED COMPANIES. ALL RIGHTS ARE RESERVED. NO PART OF THIS DOCUMENT IS TO BE REPRODUCED OR TRANSMITTED IN ANY FORM OR BY ANY MEANS, ELECTRONIC OR MECHANICAL, INCLUDING PHOTOCOPYING, RECORDING, OR BY ANY INFORMATION STORAGE AND RETRIEVAL SYSTEM. THE DOCUMENT IS EXPRESSED, IMPLIED, AND/OR ENJOINED TO BE KEPT CONFIDENTIAL. THE USER AGREES TO MAINTAIN THE CONFIDENTIALITY OF THIS DOCUMENT AND TO OBTAIN THE NECESSARY PERMISSIONS FROM SIEMENS ENERGY AND ITS AFFILIATED COMPANIES FOR ANY REPRODUCTION OR TRANSMISSION OF THIS DOCUMENT. SIEMENS ENERGY AND ITS AFFILIATED COMPANIES SHALL BE RESPONSIBLE FOR ANY VIOLATION OF THESE TERMS AND CONDITIONS. SIEMENS ENERGY AND ITS AFFILIATED COMPANIES ACCEPTS NO LIABILITY FOR ANY DAMAGE, LOSS, OR INJURY, INCLUDING CONSEQUENTIAL DAMAGES, ARISING FROM THE USE OF THIS DOCUMENT. SIEMENS ENERGY AND ITS AFFILIATED COMPANIES SHALL BE RESPONSIBLE FOR ANY VIOLATION OF THESE TERMS AND CONDITIONS. SIEMENS ENERGY AND ITS AFFILIATED COMPANIES ACCEPTS NO LIABILITY FOR ANY DAMAGE, LOSS, OR INJURY, INCLUDING CONSEQUENTIAL DAMAGES, ARISING FROM THE USE OF THIS DOCUMENT.

DESIGNER	DATE	TITLE
MRI	4/24/09	GENERAL ARRANGEMENT
CHECKER	DATE	PROJECT
MEC	4/24/09	8 GPM MODEL
ENGINEER	DATE	CLIENT
MEC	4/24/09	HPS, COLORADO SPRINGS, COLORADO
MANAGER	DATE	
ZA	4/24/09	

Water Technologies  
725 Wooten Rd, Colorado Springs  
Colorado 719-570-9600

PROJECT	DRAWING	SHEET	REV
SB000	SB000-220	1 OF 8	4