

Air Diaphragm Pump Systems

Simplex and Duplex

The Air Diaphragm Pump Systems are specifically designed to be used with a collection tank or sump. The pumps are sized to provide 50 feet (15.25 m) of head at the design flow rate. The air diaphragm pump, valves and control panel are mounted on a corrosion resistant painted steel skid. The system can be purchased as a stand alone item or used in conjunction with other standard products. When integrating with other standard products modules, the air diaphragm pump system simply interlocks with the other modules. Based on existing site conditions, the interconnecting piping (if within 3 feet (0.91 m) of the next module) is also provided with the system.

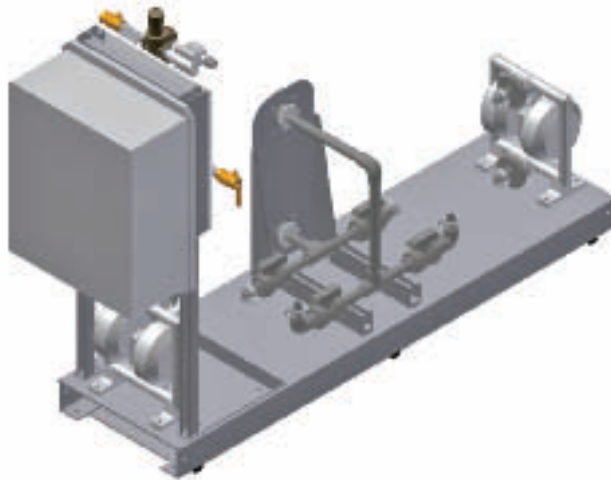

PS1.OP

Available Standard Options:

- Float level control
- Upgrade to ultrasonic control

Features:

- Isolation ball valve to service the pump
- Pre-piped
- Pre-wired
- Factory tested
- Integrate with other wastewater products

Air Diaphragm Pump Systems

Specifications									
Model Number	PS0.5C	PS0.5P	PS1.0C	PS1.0P	PS1.5C	PS1.5P	PS2.0C	PS2.0P	PS3.0C
Flowrate	2 - 8 gpm 0.5 -1.82 m ³ /h	2-10 gpm 0.5-2.3 m ³ /hr	10-40 gpm 2.3-9.0 m ³ /hr	10-40 gpm 2.3-9.0 m ³ /hr	40-90 gpm 9.0-20.0 m ³ /hr	10-100 gpm 2.3-22.7 m ³ /hr	60-100 gpm 13.6-22.7m ³ /hr	50-140 gpm 11.4-31.8 m ³ /hr	50-200 gpm 11.4-45.4m ³ /hr
Number of Air Diaphragm Pumps	One/Two		One/Two		One/Two		One/Two		One/Two
Manufacturer	ARO		ARO		ARO		ARO		ARO
Pump Type	Double Diaphragm, Air Operated		Double Diaphragm, Air Operated		Double Diaphragm, Air Operated		Double Diaphragm, Air Operated		Double Diaphragm, Air Operated
Material of Construction	Cast Iron	Polypropylene	Cast Iron	Polypropylene	Cast Iron	Polypropylene	Cast Iron	Polypropylene	Cast Iron
Flowrate @ 50' TDH	3-12 gpm 0.68-2.7 m ³ /hr	3-12 gpm 0.68-2.7 m ³ /hr	12-35 gpm 2.7-7.9 m ³ /hr	10-40 gpm 2.2-9.0 m ³ /hr	40-80 gpm 9.0-18.2 m ³ /hr	40-110 gpm 9.0-25.0 m ³ /hr	60-150 gpm 13.6-34.0 m ³ /hr	40-120 gpm 9.0-27.2 m ³ /hr	120-210 gpm 27.2-47.7 m ³ /hr
Valves and Piping Connections									
Suction	2" (50 mm) True Union Ball Valve		2" (50 mm) True Union Ball Valve		2" (50 mm) True Union Ball Valve		3" (76 mm) Butterfly Valve		4" (101 mm) Butterfly Valve
Discharge	2" (50 mm) True Union Ball Valve		2" (50 mm) True Union Ball Valve		2" (50 mm) True Union Ball Valve		3" (76 mm) Butterfly Valve		4" (101 mm) Butterfly Valve
Connection	2" (50 mm)		2" (50 mm)		2" (50 mm)		3" (76 mm)		4" (101 mm)
Instrumentation									
Level Control	Float		Float		Float		Float		Float
Skid Requirements									
Dimensions (L x W x H)	80" x 20" x 57" 2,032 x 508 x 1,448 mm		80" x 20" x 57" 2,032 x 508 x 1,448 mm		80" x 20" x 57" 2,032 x 508 x 1,448 mm		82" x 50" x 54" 2,083 x 1,270 x 1,372 mm		82" x 50" x 54" 2,083 x 1,270 x 1,372 mm
Shipping weight	500 lbs 227 kg		500 lbs 227 kg		500 lbs 227 kg		800 lbs 362 kg		800 lbs 362 kg

Siemens
Water Technologies
2000 Ericsson Drive
Warrendale, PA 15086
866.525.0621 Toll Free
724.772.6520 Phone
724.772.6521 Fax

© 2010 Siemens Water Technologies Corp.
EPWP-PSAdr-IUE-DS-1110
Subject to change without prior notice.

The information provided in this literature contains merely general descriptions or characteristics of performance which in actual case of use do not always apply as described or which may change as a result of further development of the products. An obligation to provide the respective characteristics shall only exist if expressly agreed in the terms of the contract.