

Lancy™ (IP) Solids Separator

The Lancy™ (IP) Solids Separator is a compact clarifier which uses inclined plates to remove suspended solids from wastewater. Solids enter the unit at 50–500 ppm and are typically reduced to 20–30 ppm in the corrugated plate interceptor (CPI) packs. The unit is designed to maintain a sludge blanket in the conical compartments under the CPI packs. The sludge blanket not only acts as a pre-filter but allows for a thicker sludge to be withdrawn from the clarifier. The unit can be provided as a stand alone item or in conjunction with a chemical reaction tank system.

The solids separator is manufactured with carbon steel for the basins and FRP for the corrugated plate interceptor packs.

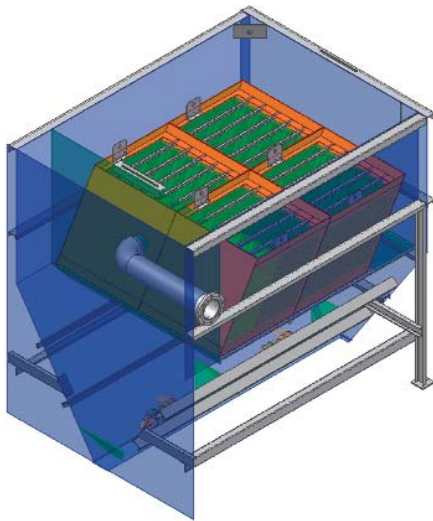

CPI-6104-120-M

FEATURES

- Up to 50% reduction in installation costs
- Up to 80% less floor space requirements
- No moving parts, less maintenance costs
- Lower operation costs, gravity does all the work
- Consistent performance
- Factory tested
- Sold as stand alone
- Integrate with other wastewater products

AVAILABLE STANDARD OPTIONS

- Coal tar epoxy or other resistant coatings
- Rapid mix and flocculation chambers
- Higher solids loadings

Lancy™ (IP) Solids Separator

| SPECIFICATIONS | | | | | | |
|-----------------------------|---|---|--|--|---|--|
| Model Number | CPI-6101-30-M | CPI-6102-60-M | CPI-6104-120-M | CPI-6106-180-M | CPI-6108-240-M | CPI-6112-360-M |
| Flow Rate | 30 gpm 6.8 m ³ /hr | 60 gpm 13.6 m ³ /hr | 120 gpm 27.3 m ³ /hr | 180 gpm 40.9 m ³ /hr | 240 gpm 54.5 m ³ /hr | 360 gpm 81.8 m ³ /hr |
| Number of Packs | 1 | 2 | 4 | 6 | 8 | 12 |
| Effective Pack Surface Area | 103 ft ² 9.6 m ² | 206 ft ² 19.1 m ² | 412 ft ² 38.3 m ² | 618 ft ² 57.4 m ² | 824 ft ² 76.6 m ² | 1,236 ft ² 114.8 m ² |
| Number of Cones | 1 | 1 | 1 | 2 | 2 | 4 |
| Sludge Withdrawal Nozzle | 6" | 6" | 6" | 8" | 8" | 8" |
| Dimensions (L x W x H) | 8'-0" x 4'-7" x 9'-3" 2,438 x 1,397 x 2,819 mm | 6'-6" x 8'-4" x 9'-9" 1,981 x 2,540 x 2,972 mm | 10'-7" x 8'-4" x 9'-9" 3,226 x 3,734 x 3,658 mm | 10'-6" x 12'-3" x 12'-0" 3,200 x 3,785 x 3,658 mm | 19'-6" x 8'-4" x 11'-0" 5,944 x 2,540 x 3,533 mm | 19'-8" x 12'-5" x 12'-0" 5,994 x 3,785 x 3,658 mm |
| Shipping Weight | 3,500 lbs 1,590 kg | 5,100 lbs 2,310 kg | 6,600 lbs 2,990 kg | 2,600 lbs 1,180 kg | 13,700 lbs 6,210 kg | 18,000 lbs 8,160 kg |
| Operating Weight | 14,800 lbs 6,710 kg | 22,500 lbs 10,200 kg | 36,100 lbs 16,370 kg | 66,300 lbs 30,070 kg | 82,800 lbs 37,560 kg | 145,000 lbs 65,770 kg |

Siemens
Water Technologies
2000 Marconi Drive
Warrendale, PA 15086
866.525.0621 Toll Free
724.772.6520 Phone
724.772.6521 Fax

© 2007 Siemens Water Technologies Corp.
All rights reserved
EPWP-CPIdr-IUE-DS-0707
Subject to change without prior notice.

Lancy is a trademark of Siemens, its subsidiaries or affiliates.

The information provided in this literature contains merely general descriptions or characteristics of performance which in actual case of use do not always apply as described or which may change as a result of further development of the products. An obligation to provide the respective characteristics shall only exist if expressly agreed in the terms of the contract.