

Auto-Shell™ Filter: Walnut Shell Filtration

More Than a Water Treatment Company, an Established Leader in Oil/Water Separation

Siemens Water Technologies offers a complete line of products to remove oily contaminants from water. Auto-Shell™ filters offer improved technology in walnut shell filtration. The patented filter design eliminates the need for flat media retention screens and uses one media scrubbing pump for multiple filter cells. This simplifies the design of the filters, and lowers the cost of multiple filter systems.

Applications

Walnut shell filtration was developed as a more suitable method of filtering free oil and suspended solids in applications where sand filters have traditionally been used. Today, walnut shell filtration is used to treat oil field produced water, refinery wastewater, steel mill direct spray and caster water, ethylene plant quench water, copper concentrate decant and cooling water.

Principle of Operation

The Auto-Shell™ filter uses a deep bed of 100 percent black walnut shells, which have excellent surface characteristics for coalescing and filtration, plus superior resilience to attrition. These filters offer a deep nutshell bed (66 in/168 cm) for superior effluent quality, longer filtration runs, and greater throughput efficiency.

Auto-Shell™ filters use raw process water for backwashing, eliminating the need for air scour, stand-by filters and additional storage tanks. The filter operates at twice the flux rate of conventional filters in the same application, and can remove over three times the amount of solids before needing to be cleaned.

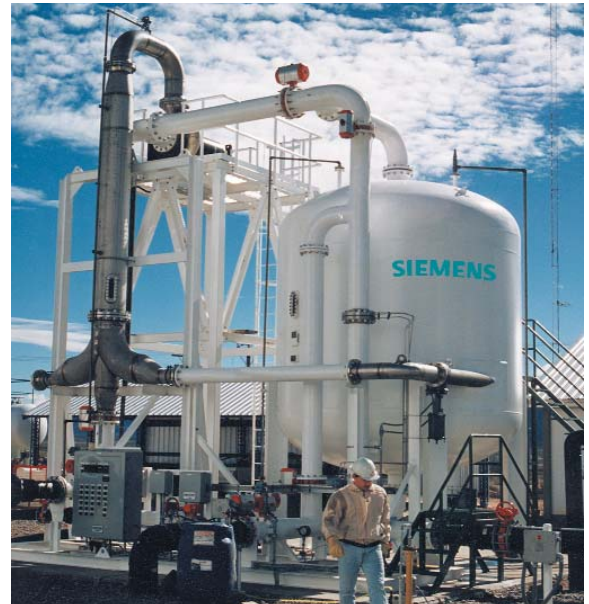

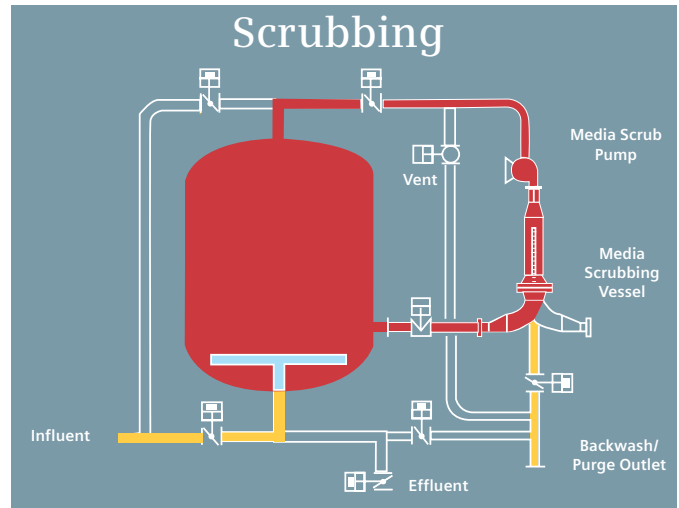
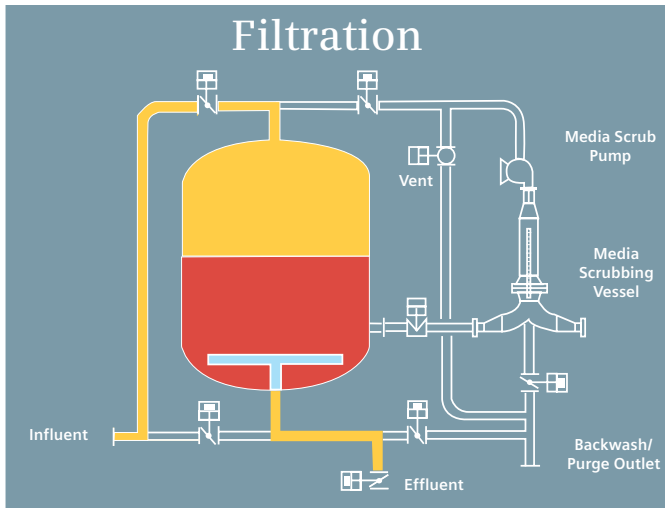

Auto-Shell™ Filter Operation

During the filtration cycle, dirty process water passes through the filter from top to bottom. As the water passes through the walnut shell media, free oil and suspended solids are removed.

After 24 hours of filtration, the dirty process water is redirected to the bottom of the vessel to fluidize the media bed. A short vent step of approximately 30 seconds frees the filter of any accumulated free oil and gas in the top of the vessel.

The media scrub pump is then turned on, causing the walnut shells to exit the vessel and circulate through the pump and the media scrubbing vessel. Shearing action of the media passing through the impeller of the specially designed media scrub pump positively cleans all of the media during each backwash cycle.

The media circulates through the media scrub pump for approximately 12 minutes. A media circuit clearing step then ensures that all of the black walnut shells are cleared from the scrub system prior to force setting of the media bed and the return to on-line filtration.

The media scrubbing vessel can effectively be used as a common media scrubbing unit for up to four filters at one time.

Flowrate		Filter Dia.	Model Number
BWPD	GPM		
1,500	43	2'-0"	AWS-24
3,250	95	3'-0"	AWS-36
5,800	170	4'-0"	AWS-48
9,000	265	5'-0"	AWS-60
13,000	380	6'-0"	AWS-72
18,000	525	7'-0"	AWS-84
23,500	685	8'-0"	AWS-96
29,500	860	9'-0"	AWS-108
36,000	1,050	10'-0"	AWS-120
44,000	1,283	11'-0"	AWS-132
52,500	1,530	12'-0"	AWS-144
61,500	1,793	13'-0"	AWS-156
71,250	2,079	14'-0"	AWS-168

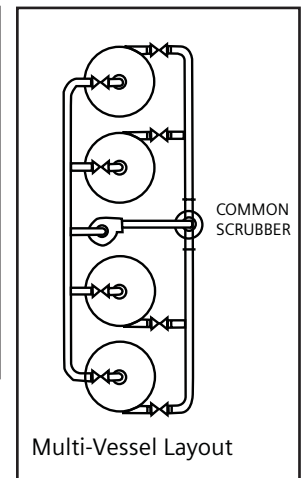

Siemens
Water Technologies
411 Commercial Parkway
Broussard, LA 70518
tel: 337.837.3071
fax: 337.837.9908
email: monosep.water@siemens.com

© 2009 Siemens Water Technologies Corp.
ZP-AUSHdr-DS-0209
Subject to change without prior notice.

Auto-Shell is a trademark of Siemens its subsidiaries or affiliates.

The information provided in this literature contains merely general descriptions or characteristics of performance which in actual case of use do not always apply as described or which may change as a result of further development of the products. An obligation to provide the respective characteristics shall only exist if expressly agreed in the terms of the contract.