

High Efficiency Liquid/Liquid Hydrocyclone

More Than a Water Treatment Company, An Established Leader in Oil/Water Separation

As a world leader in meeting your water treatment needs, Siemens Water Technologies offers the most complete line of oil/water separation equipment available from a single source.

Our liquid/liquid hydrocyclone is one of the most advanced, yet least complicated oil/water separation devices available. It provides maximum separation efficiency for the smallest space impact of the available technologies.

Principle of Operation

Hydrocyclones operate under system pressure, and use pressure drop as the primary source of energy.

Each hydrocyclone liner in a vessel is fed tangentially to initiate a high radial velocity. The spinning motion of the fluid is accelerated by the tapered shape of the hydrocyclone liner, and the spinning motion creates a centrifugal force up to 4000 G's which causes the oil and water to separate rapidly. The oil forms a core at the axis of the hydrocyclone and is forced out via a centered opening at the inlet end of the hydrocyclone liner.

The result is a simple but effective, and very compact, oil/water separator with no moving parts

Twin Ports

Our hydrocyclone liners feature twin inlet ports which provide superior hydraulic stability with a straight oil core that is stable even at very low flow rates.

The stable oil core enables the hydrocyclone to achieve higher removal efficiencies that can reduce or eliminate the need for emulsion breaking chemicals. The stability of the oil core allows the hydrocyclone to operate at turndown ratios from 5:1 to 10:1.

Superior Materials

Our hydrocyclone liners use a proprietary cobalt alloy for the high erosion potential areas of the inlet, overflow, and acceleration regions. The narrow tapered section is made of duplex stainless steel. These materials of construction provide superior erosion and corrosion resistance for a long design life.



	Model No.	A (inches)	B (inches)	C (inches)	dry weight (lbf)	wet weight (lbf)
ANSI 150# Class	V6	6.63	55.50	23.00	830	880
	V12	12.75	58.25	26.00	1,585	1,798
	V18	18.00	63.06	29.00	2,545	3,065
	V24	24.00	65.38	32.00	4,033	4,910
	V30	30.00	67.32	35.00	5,862	7,379
	V36	36.00	70.25	38.00	8,708	10,978
ANSI 300# Class	V42	42.00	74.56	41.00	11,395	14,688
	V6	6.63	56.32	23.00	974	1,025
	V12	12.75	61.63	26.00	2,058	2,281
	V18	18.00	64.63	29.00	3,657	4,184
	V24	24.00	68.88	32.00	6,043	7,042
	V30	30.00	73.13	35.00	9,834	11,476
ANSI 600# Class	V36	36.00	76.43	38.00	12,306	14,757
	V42	42.00	79.32	41.00	16,665	20,115
	V6	6.63	58.01	23.00	1,213	1,365
	V12	12.75	65.63	26.00	2,607	2,844
	V18	18.00	68.63	29.00	4,915	5,472
	V24	24.00	73.25	32.00	8,570	9,629
V30	30.00	80.25	35.00	13,182	14,971	
V36	36.00	83.51	38.00	18,533	21,214	
V42	42.00	86.63	41.00	25,758	29,476	

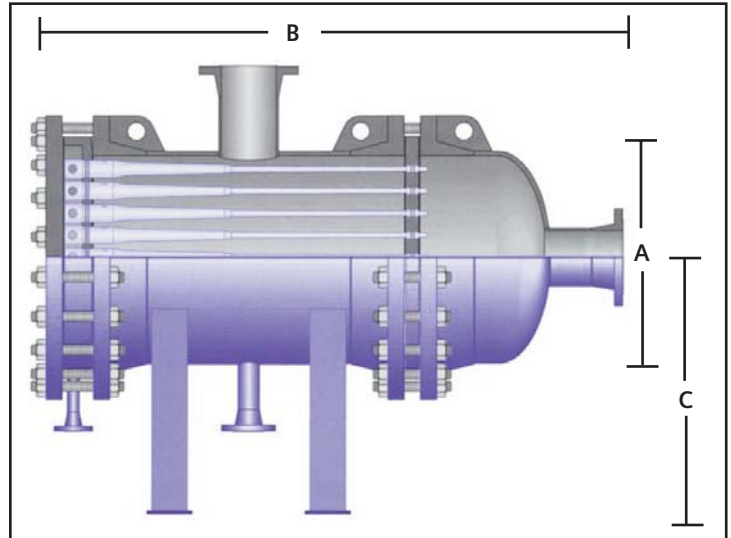

Our hydrocyclone liners have a unique, non-threaded construction which reduces manufacturing cost and eliminates galling potential, to achieve near 100 percent equipment service time.

This unique construction also reduces the overall size of the liner increasing the number of liners that can fit in a given vessel diameter.

Inensitivity to Motion

The centrifugal force generated inside the hydrocyclone liner can reach 4000 times the force of gravity in some applications, nullifying the negative effects on separation caused by wave action on floating systems.

For More Information

Contact us today to find out more about our hydrocyclones.

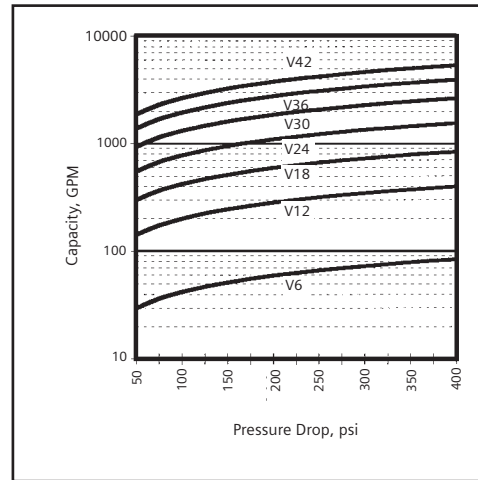

Siemens
Water Technologies
411 Commercial Parkway
Broussard, LA 70518
tel: 337.837.3071
fax: 337.837.9908
email: monosep.water@siemens.com

© 2009 Siemens Water Technologies Corp.
ZP-LLHCdr-DS-0209
Subject to change without prior notice.

The information provided in this literature contains merely general descriptions or characteristics of performance which in actual case of use do not always apply as described or which may change as a result of further development of the products. An obligation to provide the respective characteristics shall only exist if expressly agreed in the terms of the contract.