

Poly-Stage™ Odor Control System

Siemens Water Technologies offers a full range of chemical scrubber odor control systems for municipal and industrial odor control.

Poly-Stage Scrubber System

The patented Poly-stage™ chemical scrubber system is a true modular system. Individual stages are rotationally molded from high density cross-linked polyethylene.

Systems may be used in a single stage (simplex), with two stages (duplex), three stages (triplex), or four stages in a series (quadroplex). By arranging multiple stages in series higher concentrations may be treated, and different chemicals may be used in each stage to target a wide range of odorous compounds. Each stage is fitted with its own vertical recirculation pump, chemical feed system, and blowdown.

The fan is mounted at the outlet to maintain the system under negative pressure, preventing fugitive odors from escaping.

L-Series Scrubber

The small L-series scrubber is skid mounted and completely factory assembled and tested. The L-series scrubbers are designed to treat up to 1,000 cfm of odorous air.

DD-71 Scrubber

The DD-71 scrubber is a larger version of the L-series, capable of treating up to 6,000 cfm of odorous air.

Standard Features

- Patented modular system
- Removes H₂S, mercaptans, organic sulfides, ammonia and amines in one system
- Compact, low profile enables indoor installations
- Factory assembled for "plug & play" installation
- HDXLPE construction
- Siemens service and support



Poly- Stage Design Information

L-Series	Dimensions WxLxH ft	Shipping Weight	Operating Weight	Estimated System Power HP
Simplex	5 x 8 x 7.2	300	1,000	4.0
Duplex	6.3 x 8.6 x 7.2	750	1,500	5.0
Triplex	7.3 x 8.6 x 7.2	1,500	2,500	6.0
DD-71				
Simplex	3.8 x 8 x 7.6	1,800	5,000	15.0
Duplex	7 x 8 x 7.6	2,800	10,000	18.0
Triplex	11 x 8 x 7.6	4,000	15,000	22.0

Process Flow Diagram

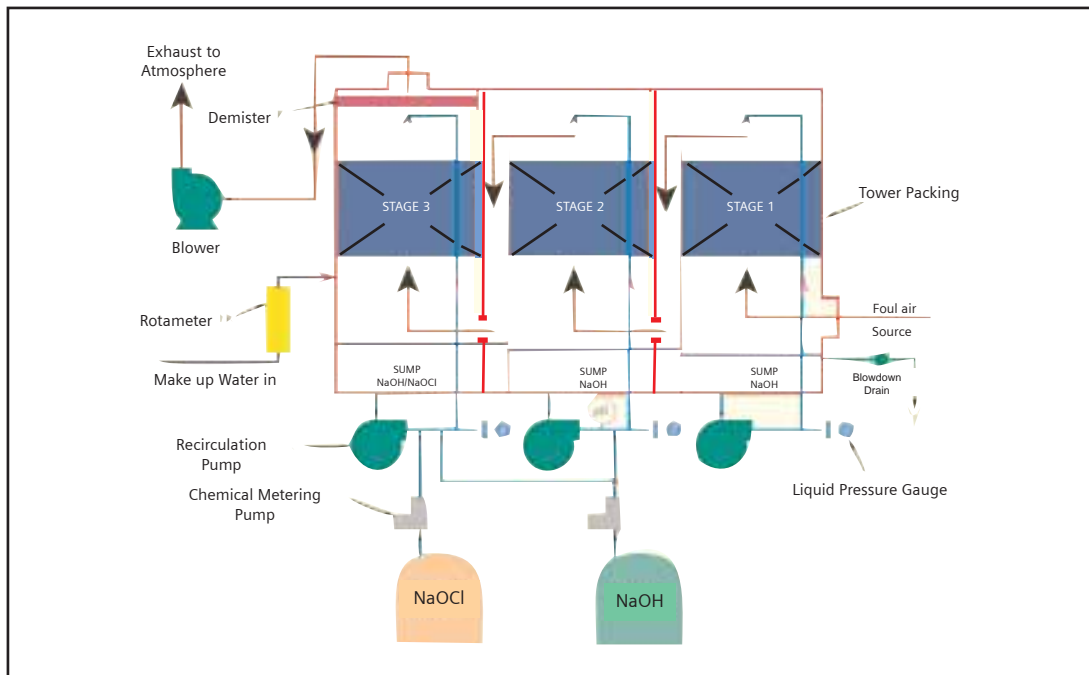

L-Series Systems



L-Series Simplex System

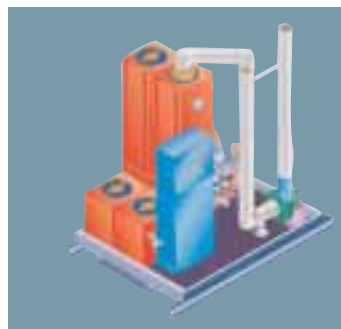

L-Series Duplex



L-Series Triplex System

Siemens
Water Technologies
12316 World Trade Drive, Suite 100
San Diego, California 92128
Phone: 858-487-2200
E-Mail: odorcontrol.water@siemens.com

© 2008 Siemens Water Technologies Corp.
OC-RJPOLYdr-DS-0308
Subject to change without prior notice.

POLY-STAGE is a Trademark of Siemens, its subsidiaries or affiliates.

The information provided in this literature contains merely general descriptions or characteristics of performance which in actual case of use do not always apply as described or which may change as a result of further development of the products. An obligation to provide the respective characteristics shall only exist if expressly agreed in the terms of the contract.

The United States Trademark office has recognized the novelty of the design and process of the POLY-STAGE with the award of a patent (U.S. Patent No. 4,948,402)