

# PolyBlend® DP800 Dry / Liquid Polymer Feed System

## Product Sheet

# SIEMENS

The PolyBlend® DP800 is a member of the family of reliable dry polymer feed systems for use in water and wastewater applications. The DP800 is an integrated equipment package capable of automatically preparing a homogeneous polymer solution.

The DP800 consists of the DD4 dry polymer disperser, a stainless steel mix tank, and a gravity fed stainless steel hold tank.

The DP800 is specifically designed to provide uniform mixing. Dry polymer and water are initially mixed in the DD4 polymer disperser exposing the solution to a high shear agitation via mechanical mixing. The high shear agitation ensures proper activation of the polymer and prevents unwanted agglomerations. After brief exposure, the solution exits the high shear mixer and flows into the mix tank.

The second stage mix is a longer, low shear mix. The rotating impeller in the secondary mix tank is a patented "hollow-wing" design and covers over half the width of the tank. The low shear mixing continuously and uniformly moves the solution vertically and horizontally resulting in no agglomerations or broken polymer chains.

When a low level is sensed in the hold tank, a valve is automatically opened and the prepared solution is gravity fed into the holding tank. From the holding tank, the homogenous polymer solution can be transferred to the process with an optional feed pump skid.

The DP800 is controlled through an easy-to-use microprocessor-based operator interface. The LCD display enables complete operation of all functions including dosage rates, solution concentration, and alarm conditions.

### Specifications

Electrical	208VAC/ 50-60 Hz/ 1 Ph 240VAC/ 50-60 Hz/ 1 Ph 480VAC/ 50-60 Hz/ 3 Ph 575VAC/ 50-60 Hz/ 3 Ph
Water Supply	20-30 GPM (75.7-113.6 LPM)
Tank Size	360 USG (1362.8 L)
*Polymer Feed	Up to 45lbs (20.4kg) /hr dry polymer based on a 0.75% solution and two (2) batches per hour
Control Panel	NEMA 4X PLC Based
Options	See Back

**\*Note:** Consult Siemens Water Technologies with regards to dosing amount and your application.



### Benefits of the PolyBlend® DP800:

- Reliable Performance
- Field Proven
- Reduced Polymer Consumption
- Fully Automated Operation
- Operator Interface Controls
- Improved Safety Features
- Easy to Operate

## General Layout

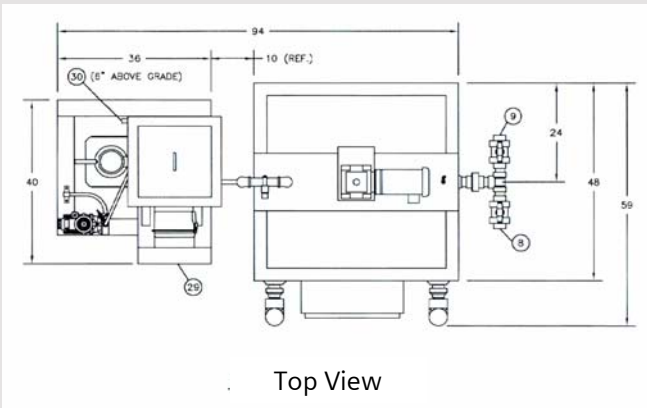
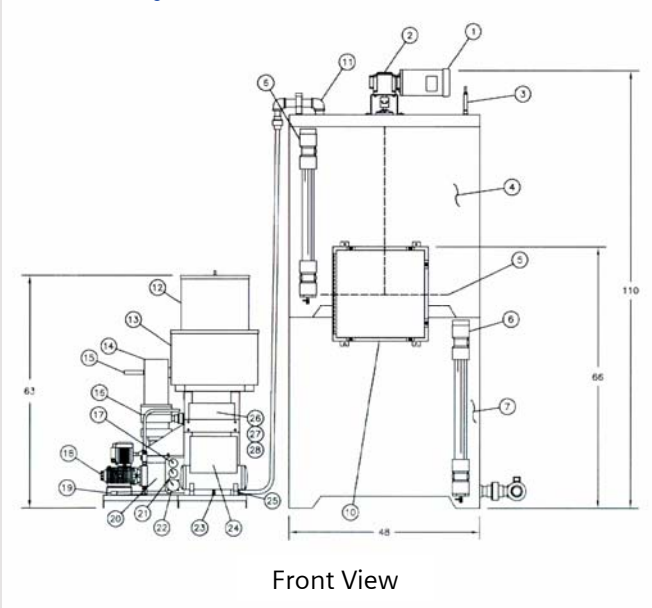

Key	Description
1	Motor, Tank Mixer, 1725 RPM, TEFC
2	Speed Reducer
3	Pneumatic Cylinder, Dump Valve Actuator
4	Mix Tank, 360 USG (1362.8 L)
5	Impeller, Mix Tank
6	Level Indicator
7	Hold Tank, 360 USG (1362.8 L)
8	Hold Tank Drain, 1-1/2" NPT (38.1mm)
9	Hold Tank Discharge, 1-1/2" NPT (38.1mm)
10	Control Panel
11	Solution Inlet, Mix Tank, 1-1/2" NPT (38.1mm)
12	Hopper, 2.5 cu/ft (0.07 cu/m)
13	Powder Feeder
14	Wetting Bowl
15	Pneumatic Cylinder, Isolation Plunger Actuator
16	Wetting Impeller Housing
17	Pressure Gauge, Compressed Air
18	Neat Liquid Polymer Pump
19	Emulsion Polymer Inlet, 1/2" NPT (12.7mm)
20	Motor, Impeller, 1.0 HP, 3450 RPM
21	Pressure Gauge, Water Supply
22	Differential Pressure Gauge with Switch
23	Condensate Drain
24	Air Compressor with Tank
25	Solution Discharge, Wetting Device, 1-1/2" NPT (38.1mm)
26	Pressure Switch, Air
27	Pressure Switch, Supply Water
28	Junction Box
29	Support Frame, Base
30	Supply Water Inlet, 1-1/2" NPT (38.1mm)

## Available Options

- Diaphragm Metering Pump
- Progressing Cavity Metering Pump
- SS Gear Metering Pump
- Batch Tanks/ Single or Tandem
- Integral Compressor
- 2.5 ft<sup>3</sup> (0.07 m<sup>3</sup>) Hopper
- 20 ft<sup>3</sup> (0.57 m<sup>3</sup>) Hopper
- Bulk Bag Frame
- Bulk Bag Frame with Hoist
- Bag Dump Hopper
- Low Powder Level Indication
- Over-Sized Feeder Screw Auger
- Supply Water Pressure Reducing Valve
- Final Feed Pumps
- Final Feed Post Dilution
- Large Hold Tanks
- Transfer Pumps

**Note:** Drawings are shown with optional liquid polymer pump and 2.5 cu/ft (0.07 cu/m) hopper. Contact Siemens Water Technologies to select proper options to meet your process requirements.

PolyBlend is a trademark of Siemens, its subsidiaries or affiliates.

The information provided in this brochure contains merely general descriptions or characteristics of performance which in actual case of use do not always apply as described or which may change as a result of further development of the products. An obligation to provide the respective characteristics shall only exist if expressly agreed in the terms of the contract.

Siemens  
Water Technologies  
595 Industrial Drive  
Bradley, IL 60915, USA  
800.809.0971 phone  
www.usfilter.com  
stranco.water@siemens.com

Literature No. ST-DP800-DS-0706  
Subject to change without notice.  
©2006 Siemens Water Technologies Corp.