

PolyBlend® Dry Polymer Feed System Model DP2000

The PolyBlend® DP2000 system is a reliable dry polymer feed system for use in water and wastewater applications. The DP2000 is an integrated equipment package capable of automatically preparing a homogeneous polymer solution.

The DP2000 consists of the DD4 dry polymer disperser, and two stainless steel mix tanks, operating in an alternate sequence.

The DP2000 is specifically designed to provide uniform mixing. Dry polymer and water are initially mixed in the DD4 polymer disperser exposing the solution to a high shear agitation via mechanical mixing. The high shear agitation ensures proper activation of the polymer and prevents unwanted agglomerations. After brief exposure, the solution exits the high shear mixer and flows into the mix tanks.

The second stage mix is a longer, low shear mix. The rotating impeller in the secondary mix tank is a U.S. patented "hollow-wing" design and covers over half the width of the tank. The low shear mixing continuously and uniformly moves the solution vertically and horizontally resulting in no agglomerations or broken polymer chains.

When a low level is sensed in one of the mix tanks, a three-way valve directs flow to the empty tank and the empty tank discharge valve closes simultaneously to isolate the empty tank from the polymer solution.

The DD4 disperser begins a makedown sequence and fills the empty tank. After the tank fill and mixing sequence is complete and the alternate tank reaches low level, the full tank discharge valve is opened and flow is directed to the polymer solution feed pumps. The three-way valve then directs flow to the empty tank, the discharge valve on the empty tank closes and the sequence repeats.

The DP2000 is controlled through an easy-to-use

Key Benefits

- Reliable performance
- Field proven
- Reduced polymer consumption
- Fully automated operation
- Operator interface controls
- Improved safety features

microprocessor-based operator interface. The LCD display enables complete operation of all functions including component status, timers, counters, etc.

Specifications

Electrical	480 VAC/ 50-60 Hz/ 3 Ph 575 VAC/ 50-60 Hz/ 3 Ph
Water Supply	113.6 LPM (30 GPM)
Tank Size	2839.1 L (750 USG)
*Polymer Feed	Up to 14.1 kg (31 lbs)/hr dry polymer based on a 0.5% solution
Control Panel	NEMA 4X PLC based
Options	See back

*Note: Consult Siemens Water Technologies with regards to dosing amount and your application.



Product Sheet

General Layout

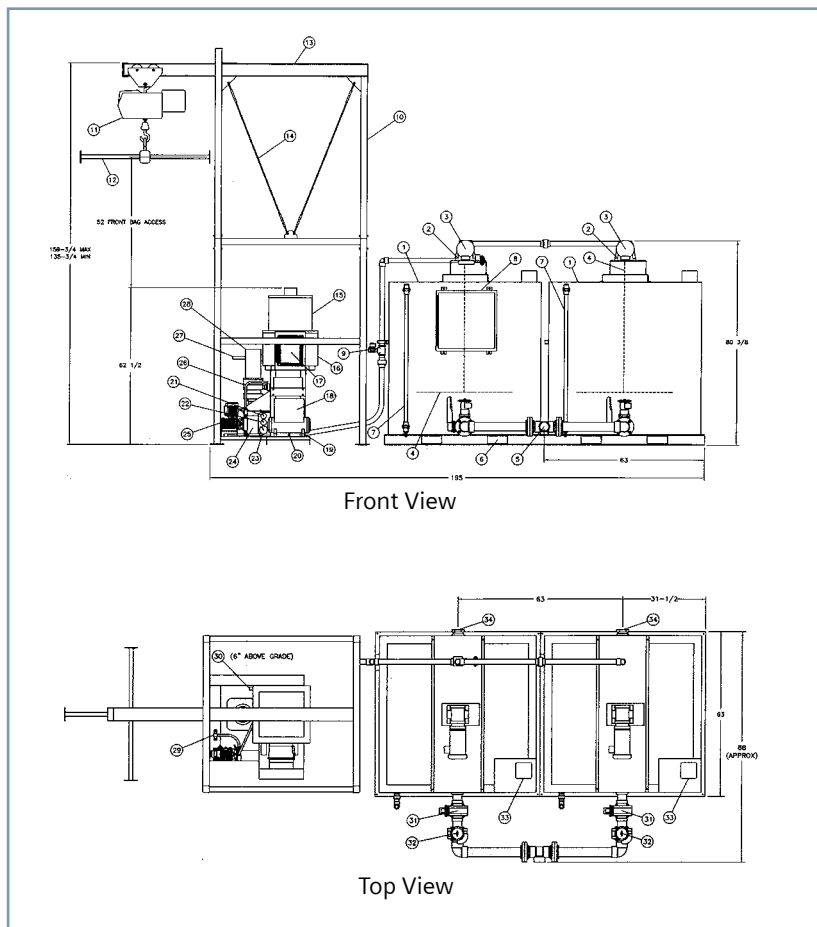

Key	Description
1	Mix Tank, 2839.1 L (750 USG)
2	Speed Reducer, Worm Gear, 30:1
3	Motor-Tank Mixer, 2.0HP, 1725 RPM, TEFC
4	Impeller—Mix Tank, 60 RPM
5	Tank Discharge, 76.2mm (3") NPT
6	Fork Truck Cutout
7	Sight Tube, Level Indication
8	System Control Panel
9	Solution Inlet, Backflow Drain, 12.7mm (1/2") NPT
10	Bulk Bag Frame
11	Hoist Motor/Trolley
12	Bag Holder
13	Mono Rail
14	Structure Cable
15	Hopper w/Collar
16	Powder Feeder
17	Junction Box, Interconnections
18	Air Compressor w/Tank
19	Solution Discharge, Wetting Device, 38.1mm (1-1/2") NPT
20	Condensate Drain
21	Pressure Gauge, Compressed Air
22	Pressure Gauge—Supply Water
23	Pressure Gauge—Differential Water
24	Motor—Impeller, 1.0 HP, 3450 RPM
25	Pump, (Diaphragm)
26	Wetting Impeller Housing
27	Pneumatic Cylinder, Isolation Plunger Actuator
28	Wetting Bowl
29	Emulsion Polymer Inlet, 12.7mm (1/2") NPT (Optional)
30	Supply Water Inlet, 38.1 (1-1/2") NPT
31	Shutoff Valve, (Manual)
32	Valve, Pneumatic Ball, Supply Water
33	Level Control, Switch Assembly
34	Tank Drain, 76.2mm (3") (F) NPT, (Capped)
35	Flow Control Valve, Water Supply

Available Options

- Diaphragm metering pump
- Progressive cavity metering pump
- Batch tanks / single or tandem
- Integral compressor
- 0.07 m³ (2.5 ft³) hopper
- 0.57 m³ (20 ft³) hopper
- Bulk bag frame
- Bulk bag frame with hoist
- Bag dump hopper
- Low powder level indication
- Supply water pressure reducing valve
- Final feed pumps
- Final feed post dilution
- Large hold tanks
- Transfer pumps

Siemens
Water Technologies

Germany
+49 8221 9040
wtger.water@siemens.com

United Kingdom
+44 1732 771777
wtuk.water@siemens.com

USA
+1 800 245 3006
dewatering.water@siemens.com

© 2008 Siemens Water Technologies Corp.
Literature No.: EP.350.490.D2K.IE.PS.1208
Subject to change without prior notice.

PolyBlend is a trademark of Siemens, its subsidiaries or affiliates. Protected by U.S. patent 5338779. NEMA is a trademark of the National Electrical Manufacturers Association.

The information provided in this literature contains merely general descriptions or characteristics of performance which in actual case of use do not always apply as described or which may change as a result of further development of the products. An obligation to provide the respective characteristics shall only exist if expressly agreed in the terms of the contract.