

AquaSaver™ Dual Direction pH Control Skid

The Siemens Water Technologies AquaSaver™ Dual Direction pH Control Skid is a totally integrated, skid-mounted treatment station. The pH Control Skid features: a reaction tank, liquid level controls, water inlet solenoid valve, centrifugal transfer pump, flow meter with control valve, dual chemical metering pumps, and electric tank mixer. The packaged skid provides economical treatment of process waste water and / or reuse of contaminated process water when used in conjunction with a Siemens Water Technologies ion-exchange system.

The system incorporates multiple tank level controls for centrifugal pump operation and make-up water addition ensuring that only properly pH adjusted water is discharged to waste or downstream to an ion-exchange system. The Strantrol® 886-L controller provides precise monitoring and control for pH adjustment, utilizing the latest electronic and sensor technology in the industry. An oversized reaction tank is equipped with an electric mixer yielding longer retention time and more accurate pH adjustment.

The system control panel offers a main on/off switch, power on light, and an emergency-stop lighted pushbutton for safety. Respective red status lights

Specifications

Electrical	120 VAC / 1 Phase / 60Hz
Maximum Flow Rate	19 GPM
Dimensions	48"W x 72"L x 5.75"H (Skid Only)
Maximum Pressure	65 PSI
Centrifugal Pump	15.85 GPM @ approximately 70 PSI, 1.5 HP, 316SS / EPDM
Water Inlet	1" Solenoid Valve, PVC/ Viton®
Discharge Outlet	1" PVC / Viton® (F)NPT
Accumulation Tank	150 Gallon w/ Hinged Cover, HDPE
Process Range	2-19 GPM, 50+ PSI

Key Benefits

- Pre Ion-Exchange or Waste Water pH Adjustment
- Multiple Tank Control Levels
- Optional Dual Cartridge Filtration
- pH Down and pH UP Operational Modes
- Mixer for Quick and Thorough pH Adjustment
- Strantrol® 886 Controller for Precise & Reliable pH Control
- Powers Dual loop process controller with adaptive tune technology provides Acid and Base pump feed control

indicate when the centrifugal pump, inlet solenoid valve, chemical pumps, and mixer are on. Individual HOA switches permit selection of the operation mode for the centrifugal pump and inlet solenoid valve via level controls, and the chemical pumps and mixer via the Strantrol® pH controller and dual loop process controller. Amber indicating lights are also present for low-level and high-level tank alarms.



Product Sheet

General Layout

Key	Description
1	Tank Isolation Valve, 1" PVC/Viton®
2	Tank / Process Drain, 1" PVC/Viton® (F)NPT
3	Y-Strainer, 1", PVC/Viton®
4	Tank, 150Gal, w/Hinged Cover, HDPE
5	Chemical Feed Inlet, Sulfuric Acid, PP/PVDF/Viton®
6	Chemical Feed Inlet, Sodium Hydroxide, PVC/PVDF/EPDM
7	Level Probe, PP/PVDF, Four Point, Float Type, 2" NPT
8	Discharge Outlet, 1" PVC/Viton®, F(NPT)
9	Tank Mixer
10	Water Inlet, 1" Solenoid Valve, PVC/Viton®
11	pH Probe Bulkhead Fitting
12	(2) Pump, 2.5GPH @ 100 PSI, Model# B921-393SI
13	Pump, 15.85 GPM @ 250 PSI, 1.5HP, 316SS/EPDM
14	Back Pressure Valve, 1" PVC/PVDF
15	Gauge w/Guard, 0-200PSI, 1/2" PVC/PTFE
16	Discharge Bleed, 1" PVC/Viton® (F)NPT

Key	Description
17	Rotometer, 1.5", PVC/Viton®/PVDF/Polysulfone
18	Globe Valve, 1" PVC/Viton®
19	pH Controller, Strantrol® 886-L Controller
20	Local Control Panel, See SP14004 for Details
21	Skid, 48"x72"x5.75", HDPE w/Forklift Slots
22	Pressure Relief Valve, 1" PVC/PTFE, 50PSI Setpoint

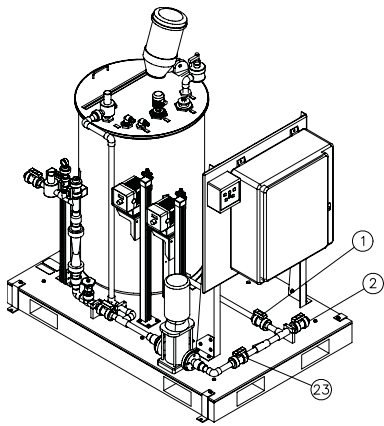

Isometric View

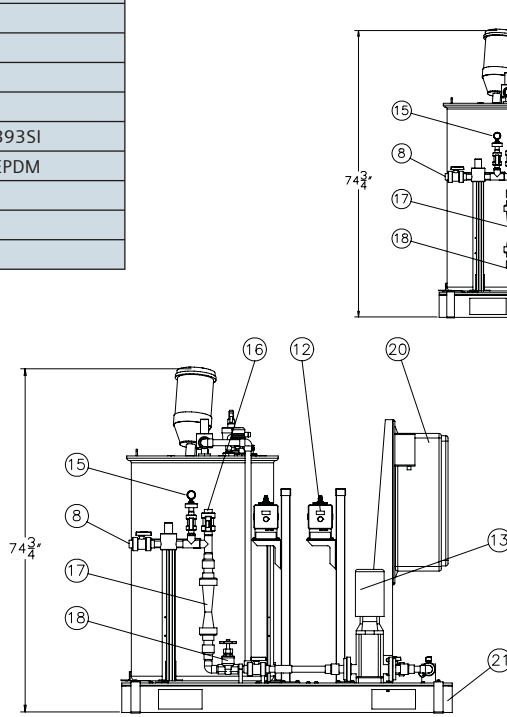

Top View

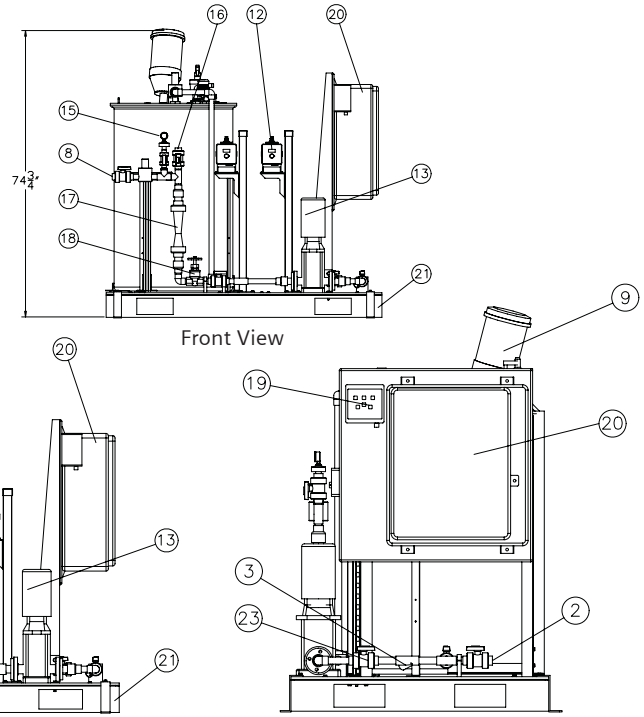

Front View

Side View

Elementary P&ID

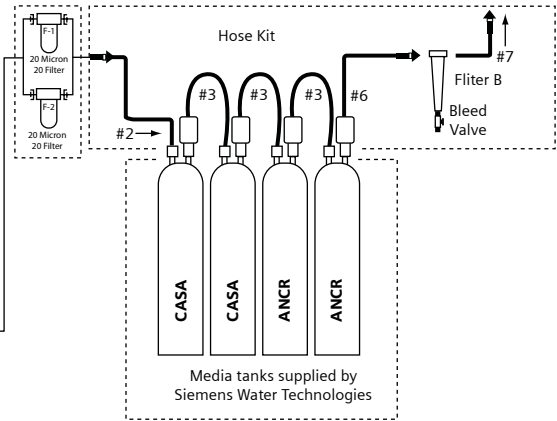
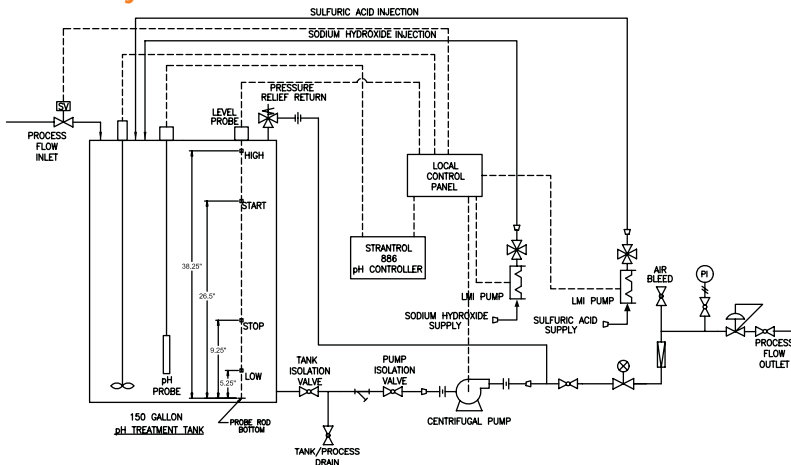

Siemens
Water Technologies

USA
+1 800.245.3006
dewatering.water@siemens.com

AquaSaver and Strantrol are trademarks of Siemens, its subsidiaries or affiliates. NEMA is a trademark of the National Electrical Manufacturers Association. Viton is a trademark of DuPont Performance Elastomers, LLC.

© 2008 Siemens Water Technologies Corp.
Literature No.: EP.410.200.001.UA.PS.0108
Subject to change without prior notice.

The information provided in this literature contains merely general descriptions or characteristics of performance which in actual case of use do not always apply as described or which may change as a result of further development of the products. An obligation to provide the respective characteristics shall only exist if expressly agreed in the terms of the contract.