

Sulfuric Acid Chemical Feed Skids

The Sulfuric Acid Feed Skid is engineered for dual chemical feed applications. The skid is designed with two primary DC motor driven pumps and a third backup pump. A flow sensor monitors the discharge of each pump. A visual alarm is activated with loss of flow of either pump. Under no flow conditions, the automatic switch over circuit opens the proper motorized ball valve and energizes the output to power the backup pump.

The system is mounted on a polypropylene base with a common suction line and separate discharge connections. All plumbing, including the isolation valves, is constructed of PVDF. Back pressure valves and pressure relief valves are also included. A 500ml calibration cylinder is supplied to confirm dosage rates.

The NEMA 4X enclosure is mounted on the skid with Hand-Off-Auto switches and status lights for each pump. The motors are connected to a SCR drive allowing variable speed control via external input signals.

Key Benefits

- Reliable, Dual Chemical Feed with Backup
- PVDF Piping for Maximum Compatibility
- Automatic Pump Switchover
- Integrated Controls with Variable Speed Control
- Complete System / Start-Up Ready

Specifications

Power	115VAC / 1 Phase / 60 Hz / 24A
Dimensions (H x W x D)	50" x 47" x 39"
Pump	26GPH, 150PSI, 90 VDC Motor PVDF / TFE (3 ea)
Materials of Construction	PVDF, Viton®, Teflon
Chemical Inlet	3/4" (F)NPT
Chemical Discharge	1/2" (F)NPT



Product Sheet

General Layout

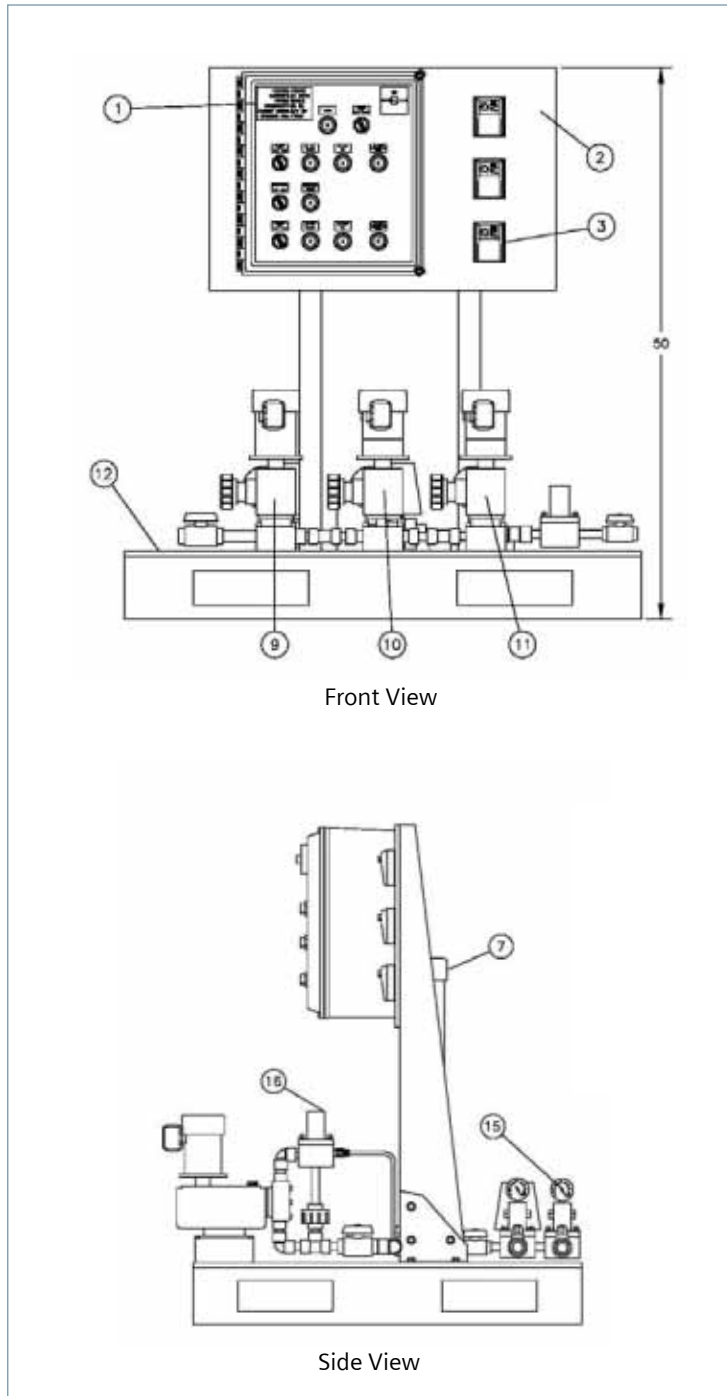

Key	Description
1	Control Panel
2	PVC Backboard 30" x 20" x 5 ³ / ₄ "
3	SCR Motor Speed Control (Qty. 3)
4	#2 Discharge 1/2" FNPT
5	1/2" Motorized Ball Valve (Qty. 2)
6	#1 Discharge 1/2" FNPT
7	500ml Calibration Cylinder
8	Chemical Inlet, 3/4" FNPT
9	#1 Pump, 29 GPH, 150 PSI
10	Backup Pump, 29 GPH, 150 PSI
11	#2 Pump, 29 GPH, 150 PSI
12	Skid, Poly, 47" x 39" x 5 ³ / ₄ "
13	Back Pressure Valve (Qty. 2)
14	Flow Sensor (Qty. 2)
15	Pressure Indicator (Qty. 2)
16	Pressure Relief Valve (Qty. 2)

Siemens
Water Technologies

USA
+1 800 245 3006
dewatering.water@siemens.com

© 2008 Siemens Water Technologies Corp.
Literature No.: EP.410.245.000.UA.PS.1208
Subject to change without prior notice.

NEMA is a trademark of the National Electrical Manufacturers Association. Viton is a trademark of DuPont Performance Elastomers LLC. Teflon is a trademark of E.I. du Pont de Nemours Company.

The information provided in this literature contains merely general descriptions or characteristics of performance which in actual case of use do not always apply as described or which may change as a result of further development of the products. An obligation to provide the respective characteristics shall only exist if expressly agreed in the terms of the contract.