

PolyBlend® Polymer Feed System PB Series (Small Frame)

The PolyBlend® PB Series liquid polymer feed system is the most popular polymer feed system offered with over 10,000 units in service worldwide. The PolyBlend® PB Series combines years of technical expertise with simple operation to provide an inexpensive means to maximize polymer activation.

The compact design of the PolyBlend® PB Series provides easy installation. The corrosion-resistant, stainless steel chassis houses the lightweight, portable system, allowing for easy mobility. The simple-to-use electronic controls and adjustable flow meter permits precise water control for a variety of solution concentrations. In addition, the PB200 Series is designed with a secondary flow meter and static mixer for additional post-dilution.

At the center of the PolyBlend® PB Series polymer feed system is the multi-zone mixing chamber, which is patented in the U.S. The advanced design provides uniform dispersion energy at the moment of initial wetting. The high-energy mix prevents agglomerations and eliminates the need for extended mixing and aging by applying the right energy at the right time. The low energy zone continues to activate the hydrated polymer without destroying the fragile polymer chains. The result is maximum polymer activation and improved polymer performance.

Key Benefits

- Trusted and proven technology providing maximum polymer activation
- Simple electronic controls for easy operation
- Compact design with a minimal footprint

Model Selection

Model	Water Flow Rate LPH / (GPH)	Diaphragm Pump Output LPH / (GPH)
PB16-0.4	3.7-60 / (1-16)	0.015-1.58 / (0.004-0.42)
PB16-1	3.7-60 / (1-16)	0.04-3.78 / (0.01-1)
PB50-0.4	15-189 / (4-50)	0.015-1.58 / (0.004-0.42)
PB50-1	15-189 / (4-50)	0.04-3.78 / (0.01-1)
PB100-0.4	38-375 / (10-100)	0.015-1.58 / (0.004-0.42)
PB100-1	38-375 / (10-100)	0.04-3.78 / (0.01-1)
PB200-0.4	38-757 / (10-200)	0.015-1.58 / (0.004-0.42)
PB200-1	38-757 / (10-200)	0.04-3.78 / (0.01-1)
PB200-2	38-757 / (10-200)	0.07-7.57 / (0.02-2)



Product Sheet

PB16, PB50, & PB100 Standard Layout

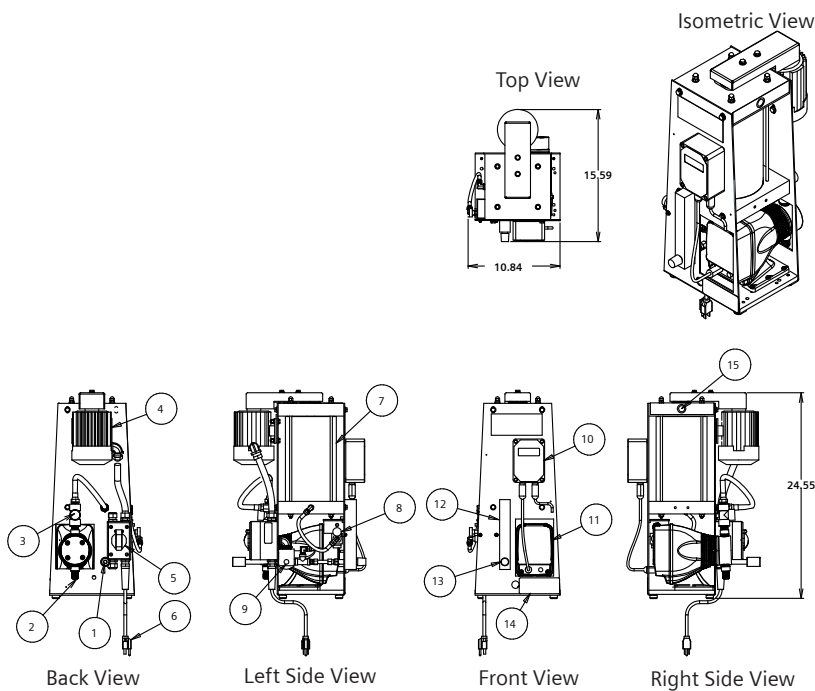

Key Description	
1	Water Inlet, 1/2" (F)NPT (12.7 mm)
2	Polymer Inlet, 5/8" O.D.Barb (15.9 mm)
3	Pump, Priming Kit Connection
4	Mixer Motor
5	Mixer Motor Switch w/ Thermal Overload
6	Power Cord
7	Mix Chamber
8	Differential Pressure Switch
9	Solenoid Valve, (Water)
10	Digital Display Pump Controller, (REM-1F)
11	Diaphragm Pump
12	Rotameter
13	Rate Valve
14	Serial Plate
15	Solution Discharge, 1/2" (F)NPT (12.7 mm)

PB200 Standard Layout

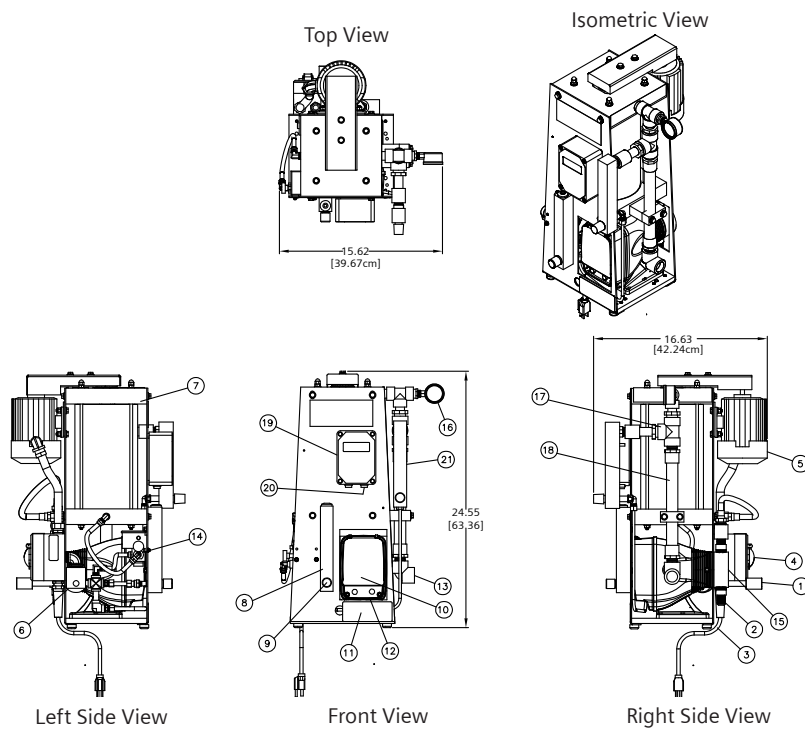

Key Description	
1	Water Inlet, 1/2" (F)NPT (12.7 mm)
2	Polymer Inlet, 5/8" O.D.Barb (15.9 mm)
3	Power Cord
4	Mixer Motor Switch w/Thermal Overload
5	Mixer Motor
6	Solenoid Valve, (Water)
7	Mixing Chamber
8	Primary Rotameter
9	Rate Valve
10	Diaphragm Pump
11	Serial Plate
12	External Input Signal Connector
13	Solution Output, 3/4" (F)NPT (19.05 mm)
14	Differential Pressure Switch
15	Priming Port, (Polymer)
16	Pressure Gauge
17	Confluence Assembly
18	Static Mixer
19	Digital Display Pump Controller, (REM-1F)
20	4-20mADC Input
21	Secondary Rotameter

Siemens
Water Technologies

Germany
+49 8221 9040
wtger.water@siemens.com

United Kingdom
+44 1732 771777
wtuk.water@siemens.com

USA
+1 800 245 3006
dewatering.water@siemens.com

© 2009 Siemens Water Technologies Corp.
Literature No.: EP.480.210.P10.IE.PS.0509
Subject to change without prior notice.

PolyBlend is a trademark of Siemens, its subsidiaries or affiliates. Protected by U.S. patents 5284626 and 5284627.

The information provided in this literature contains merely general descriptions or characteristics of performance which in actual case of use do not always apply as described or which may change as a result of further development of the products. An obligation to provide the respective characteristics shall only exist if expressly agreed in the terms of the contract.