

# Water Champ® System Control Panel

## General Description

The Water Champ® System Control Panel is specifically designed to offer ultimate protection for your submersible Water Champ® Chemical Induction System. The Control Panel includes the new Motor Protection Device (MPD).

Computer technology is applied to provide a unique system of detecting overloads, underloads, rapid cycling, ground faults, temperature, current and voltage unbalance. The Motor Protection Device will turn off the Water Champ® system should any of these faults occur and provide a visual display of the fault condition. In addition, the Motor Protection Device offers automatic restart when the problem is temporary, or can signal an alarm or backup system if it is constant.

The Water Champ® Control Panel is housed in a NEMA 4X corrosion resistant enclosure with a viewing window for all operator usable functions and diagnostics.

The easy access control panel allows the user to adjust the reset time and provides real-time voltage and current status to ensure peak performance.

## Key Benefits

- Control start/stop of Water Champ® System (locally and remotely)
- Phase reversal protection
- Three phase disconnect with lockout capability
- Surge arrester which exceeds ANSI / IEEE standard C62.11



## Product Sheet

## Motor Protection Device System

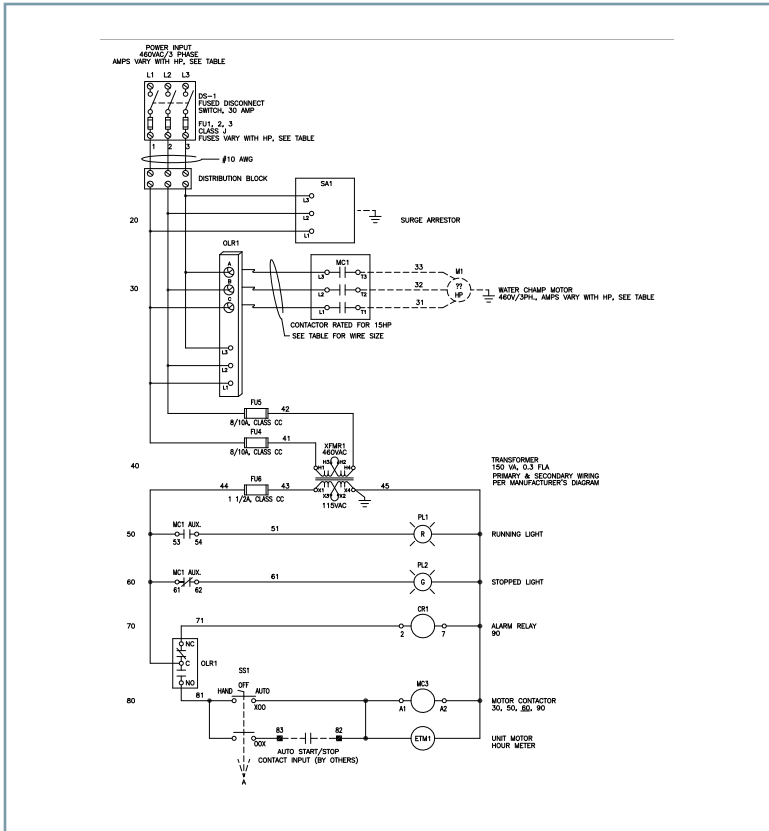

### Motor Protection Device: How It Works

A microprocessor is the main element of the Motor Protection Device system. It continuously monitors the motor's operating condition. The Motor Protection Device will immediately shut down the motor if a fault condition occurs. To assure that conditions are not temporary, the Motor Protection Device will attempt to restart the motor. If the alarm condition still exists after three restart attempts, a manual restart is required.

The Motor Protection Device protects the Water Champ® System from a variety of application conditions by monitoring some very simple inputs. The Motor Protection Device monitors motor current draw and trips if the amps are either too high, too low, or unbalanced (both overload and underload trip points are field adjustable). In the event of a fault, the Motor Protection Device forces the motor to remain disengaged at least three minutes between run cycles.

Siemens  
Water Technologies  
  
Germany  
+49 8221 9040  
wtger.water@siemens.com

United Kingdom  
+44 1732 771777  
wtuk.water@siemens.com

USA  
+1 856 507 9000  
wtus.water@siemens.com

© 2008 Siemens Water Technologies Corp.  
Literature No.: WT.070.318.SCP.IE.PS.1208  
Subject to change without prior notice.

Water Champ is a trademark of Siemens, its subsidiaries or affiliates. ANSI is a trademark of the American National Standards Institute. NEMA is a trademark of the National Electrical Manufacturers Association. IEEE is a trademark of the Institute of Electrical and Electronics Engineers, Inc.

The information provided in this literature contains merely general descriptions or characteristics of performance which in actual case of use do not always apply as described or which may change as a result of further development of the products. An obligation to provide the respective characteristics shall only exist if expressly agreed in the terms of the contract.