

Strantrol® Feed Verification Controller (FVC)

Product Description

Strantrol® FVC Stand Alone System

Siemens' Strantrol® Feed Verification Controller (FVC) provides accurate and reliable dosing measurement for a wide selection of metering pumps. The Strantrol® FVC controller controls and verifies the liquid chemical feed rate of actual chemical dispensed. A proportional feedback signal changes either the stroke rate of the pump or the 4-20mA output compensating for changes in pump output.

The Strantrol® FVC controller is configured with a 4-20mA flow verification output for remote display or data logging. In addition, the user can use a remote 4-20mA signal to change the ml/min setpoint. The Strantrol® FVC controller provides an alarm contact output along with a visual LED to alert of any chemical feed problems.

The electronics are enclosed in a NEMA 4X enclosure and the system is pre-assembled on a PVC backplate for easy installation and operation.

Strantrol® FVC Controller with PLC Option

The FVC controller with optional PLC control expands capabilities and functions. The PLC option allows up to four (4) FVC inputs, up to four (4) FVC remote setpoint outputs, and up to four (4) flow recorder outputs. The PLC option allows the user to control chemical feed based on blowdown or make-up rate. Other features of the PLC option include water totalizing, chemical inventory, data logging, and inventory control.

The FVC controller with PLC option comes in a NEMA 4X enclosure with a touch screen. The system is preassembled and wired for simple installation and operation.

Key Benefits

- Provides accurate flow measurement & control based on actual volume
- Controls pulse or 4-20 mA input pumps and is pre-assembled for easy installation
- Optional PLC based control for multiple pumps
- Optional PVDF construction available for special applications



Product Sheet

Strantrol® FVC Stand Alone System

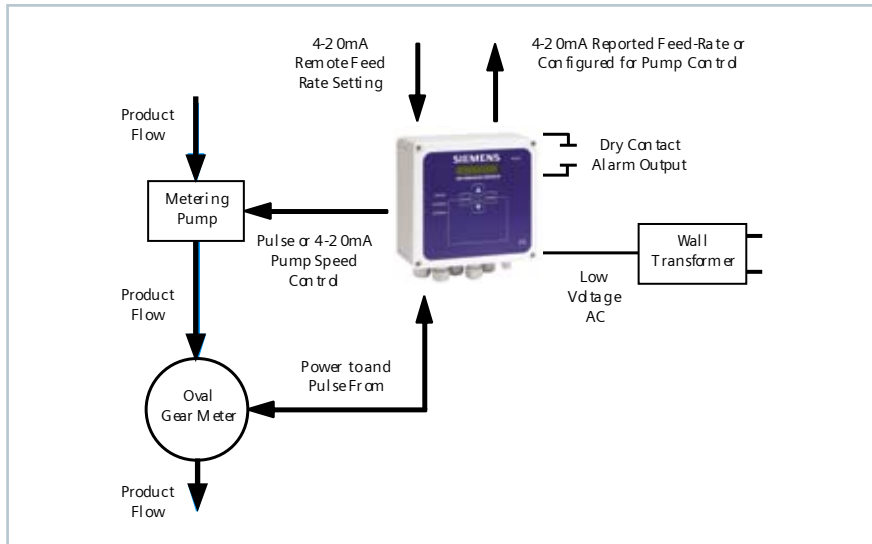

Strantrol® FVC System with PLC Option

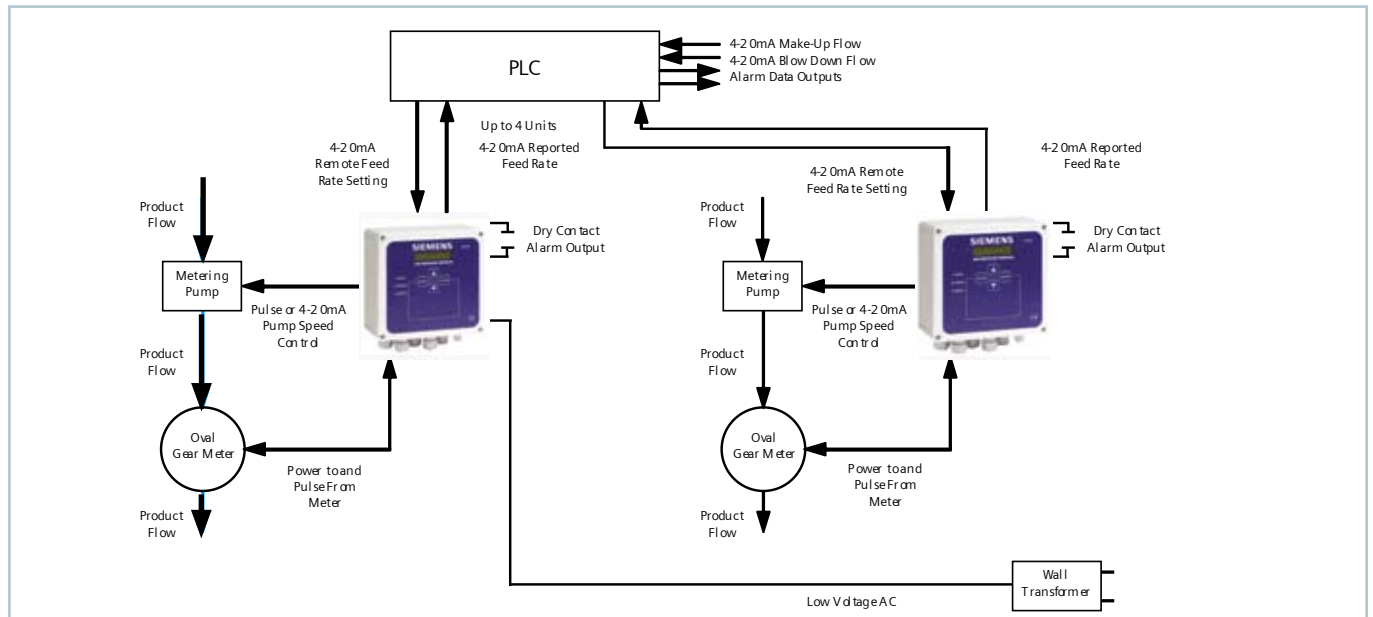

Oval Gear Meter Flow Ranges

| | | Type .1 FVC 1.6 | Type 1 FVC 16 | Type 2 FVC 32 | Type 4 FVC 63 | Type 10 FVC 160 | Type 20 FVC 320 |
|-------------|------------------------------|--------------------|------------------|------------------|------------------|--------------------|--------------------|
| GPH minimum | Non-pulsing or pulsing pumps | 0.04 | 0.79 | 1.59 | 3.17 | 7.93 | 15.85 |
| GPH maximum | Non-pulsing pumps | 1.59 | 15.85 | 31.70 | 63.40 | 158.50 | 317.01 |
| | Pulsing pumps | 0.79 | 7.93 | 15.85 | 31.70 | 79.25 | 158.5 |

Siemens
Water Technologies

Germany
+49 8221 9040
wtger.water@siemens.com

United Kingdom
+44 1732 771777
wtuk.water@siemens.com

USA
+1 866 766 5987
stranco.water@siemens.com

© 2009 Siemens Water Technologies Corp.
Literature No.: ST.470.400.FVC.IE.PS.0309
Subject to change without prior notice.

Strantrol is a trademark of Siemens, its subsidiaries or affiliates. NEMA is a trademark of the National Electrical Manufacturers Association.

The information provided in this literature contains merely general descriptions or characteristics of performance which in actual case of use do not always apply as described or which may change as a result of further development of the products. An obligation to provide the respective characteristics shall only exist if expressly agreed in the terms of the contract.