

Wallace & Tiernan® Analyzers/Controllers

SFC PC

Process controller

General

The Wallace & Tiernan® SFC PC process control unit is specifically designed for automatic control of disinfection, de-chlorination and chemical feed in water conditioning or industrial process applications. Typically used as a setpoint controller, the SFC PC system provides accurate control of gas feed equipment, as well as chemical metering pumps. Easy operation, setup and calibration using intuitive menu navigation makes sophisticated control functions simple.

Typical applications

- Potable water treatment
- Waste water treatment
- Cooling water circuits
- Industrial and process water treatment
- Swimming pools

Features

The SFC PC unit is available either as a stand alone, wall-mounted unit, equipment-mounted, or panel-mountable unit for installation in a control enclosure.

The SFC PC process controller features a choice of four control modes:

- Compound loop – the use of “fuzzy-logic” auto-tuning control technology adapts the controller action to provide a quick response with minimal deviation from the setpoint
- Single feedback or direct residual – ideal for use in closed loop systems
- Feed forward
- Flow proportional

Benefits:

- Choice of four field-selectable control modes, including process optimized, adaptive control
- Can be combined with appropriate measurement flow cell as a single analyzer/controller package
- Graphical display of all parameters and process variables
- Intuitive menu navigation for easy operation
- User configurable alarm relays for any of 16 different conditions
- Galvanically isolated inputs and outputs



SFC PC process controller

Product Sheet

Water Technologies

SIEMENS

Integral control functions of the SFC PC

There are four control programs built into the SFC software that are available for controlling one chemical feed parameter. The control output can be used to adjust the V-notch actuator on a chlorinator, or the stroke length actuator on a metering pump, or the speed of a chemical pump motor to maintain an effective treatment process.

Available control types include:

- **Flow proportional control** to adjust feedrate based on process flow. This type of control typically uses a 0/4 – 20 mA signal from a flowmeter and controls an output that is proportional to the flow. The output can be adjusted by changing the dosage factor either through the keypad and menu or through a remote mA input.

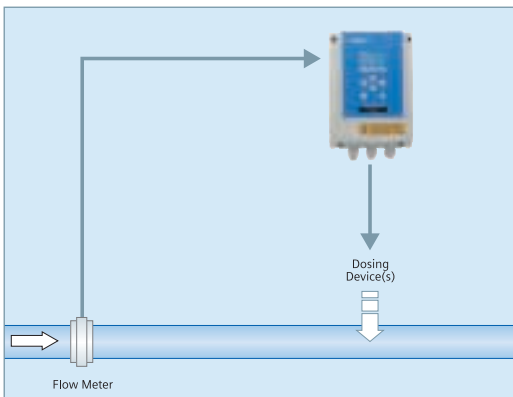

- **Single feedback or direct residual closed-loop control** to maintain a desired setpoint based on a measured value. The measured signal (either from an external measurement device or an optional measurement module) is compared with an internal setpoint, entered through the keypad or an external setpoint through a remote mA input. The source of the setpoint can be selected via a digital input. Any deviation from the control setpoint initiates a proportional/integral correction to the chemical feed device. The action of this controller can be forward acting (for chlorination) or reverse acting (for dechlorination). This type of control provides a stable residual in applications where the quality of the water varies, but the flow of the treated water is relatively constant.

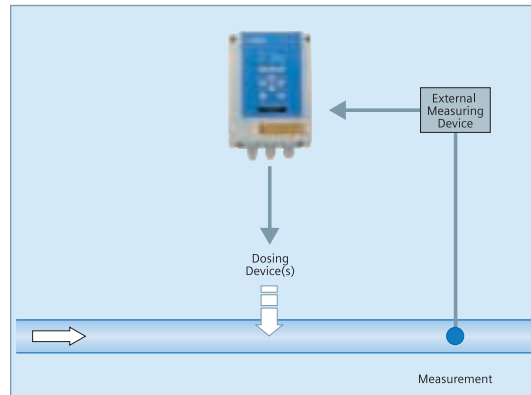

- **Feed forward control** to adjust the chemical feedrate in proportion to an external measurement input or an input from an optional measurement module in combination of a flow input. A typical example of feed forward control is chemical feed of a dechlorination chemical based on a chlorine residual analysis and treated water flowrate. The chemical feed output is derived by the controller by multiplying the treated water flow by the measurement input and applying a selected dosage factor.

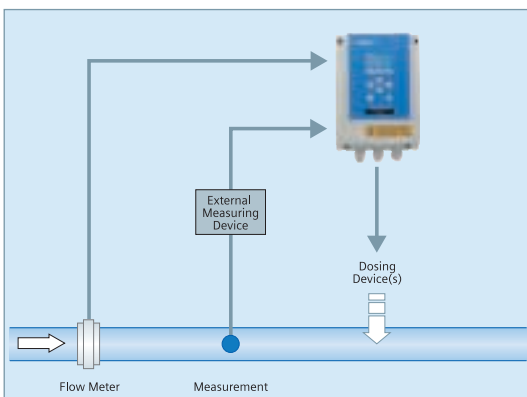

- **Compound loop control** to maintain a desired setpoint based on a measured value (either from an external measurement device or an optional measurement module) and a treated water flow input. Compound loop control utilizes a residual setpoint similar to direct residual control but incorporates a flow input in the control algorithm to quickly compensate control for variations in the flow of the treated water. This provides a stable residual regardless of changes in water quality or flow. As an added benefit, this control loop can be selected with an adaption mode for quicker reaction to changes in flow. This control algorithm includes “fuzzy logic” which acquires the correct dosage factors for different flow rates and stores them in a look-up table. The SFC controller utilizes this look-up table to adjust control whenever there is a change in the flow rate. This avoids oscillations in the residual level when there is disturbance in the flow, since the controller “knows where to go” before the residual is affected.

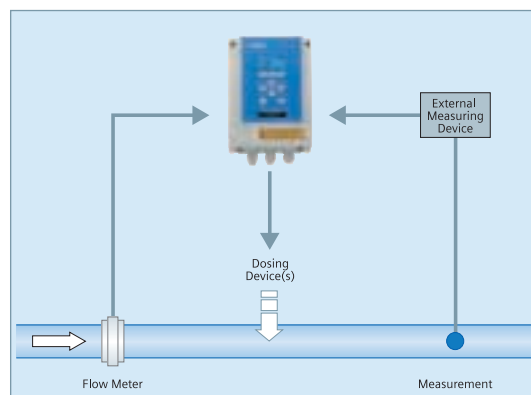

| SFC electronic module | |
|-----------------------------|---|
| Display | Back-lit LCD display, 128 x 64 pixels resolution inputs for measured concentration input, flow input and external setpoint |
| Measurement input | 3 x 0/4 – 20 mA or 0 – 1 V or 1 k Ω |
| Operating ranges | Ranged to match the residual analyzer as follows: 0 to 0.1 up to 50.0 mg/l. For center zero operation with the Deox/2000 [®] analyzer, 0.5 mg/l SO ₂ to 0.5 mg/l Cl ₂ up to 10.0 mg/l SO ₂ to 10 mg/l Cl ₂ |
| Digital inputs | 2 |
| Switching outputs (relays) | 4 alarm/control relays |
| Analog output | 0/4 – 20 mA, load protected \leq 500 Ω Accuracy < 0.5 % FS Galv. isolated up to 50 V relative to earth |
| Communication interface | RS 485 port for connection to a ChemWeb-Server, OPC-Server, CMS software, CAN sensor/actuator bus interface, RS 232 for firmware updates and slot for field bus modules |
| Power supply | 24 V DC or 100 – 240 V AC, 50/60 Hz |
| Operating temperature range | 0 – 50 °C (32 – 122 °F) |

| | |
|--------------------------|--|
| Enclosure | IP 66, designed to meet NEMA 4X |
| Installation options | Wall mounted, equipment or panel mounted |
| Trend graph | 7-day trend graph for historical reference and analysis; 30-day available with optional SD card |
| Weight (incl. packaging) | approx. 2.5 kg (5.5 lbs) |
| Dimensions (W x H x D) | 185 x 265 x 145 mm (7.3 x 10.4 x 5.7 ") |
| Testing and marking | Inspected for EMC in accordance with EN 61326; Tested for electrical safety in accordance with EN 61010 CE marking; UL listed; CSA certified |
| Extras | Real-time clock, battery operated Flash-Memory (max. 512 kB, 20 kB RAM) |
| SD card, optional | 30 days trend for two measurands |
| Proportional gain | Keypad adjustable from 1 – 1000 % |
| Integral gain | Keypad adjustable from 0 – 100 minutes |
| Lag time | Keypad adjustable from 1 – 60 seconds |
| Security access | 3-digit lock code for changing operating parameters |

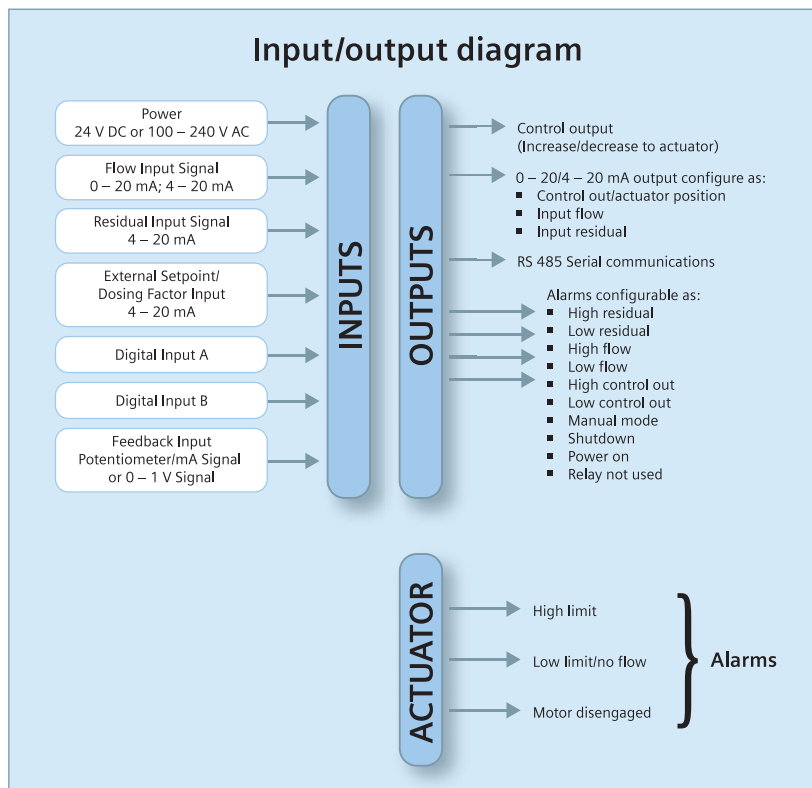

Siemens
Water Technologies

Germany:
+49 8221 9040
wtger.water@siemens.com

United Kingdom:
+44 1732 771777
wtuk.water@siemens.com

USA:
+1 856 507 9000
wtus.water@siemens.com

© 2008 Siemens Water Technologies
WT.050.590.010.IE.PS.0708
Subject to change without prior notice.

Wallace & Tiernan and Deox/2000 are trademarks of Siemens, its subsidiaries or affiliates. CSA is a trademark of the Canadian Standards Association. NEMA is a trademark of the National Electrical Manufacturers Association. UL is a trademark of Underwriters Laboratories, Inc.

The information provided in this brochure contains merely general descriptions of characteristics of performance which in case of actual use do not always apply as described or which may change as a result of further development of the products. An obligation to provide the respective characteristics shall only exist if expressly agreed in the terms of contract.