

Wallace & Tiernan® Liquid Feed Systems

Chem-Ad® Series B Metering Pump

The Chem-Ad® Series B electronically controlled, motor driven diaphragm metering pump is designed for dependable reliable metering of fluids even at minimum feedrates. A standard PVDF head and valve set provide greater resistance to most chemicals.

The Chem-Ad® Series of diaphragm metering pumps are designed to handle the most demanding applications in the treatment of potable water, swimming pools, wastewater and industrial processes. A well-balanced range of capacities combines with excellent reproducibility and optimal chemical resistance. Chem-Ad® metering pumps are of the positive displacement-type driven by proven overload-proof motors. Since they are available with a wide choice of configurations ranging from manual to flow proportional to setpoint, these pumps can cover any metering requirement.

The XL Series features an integrated LED display panel, touch-pad controls and multiple control functions, including feedrate setpoint with closed-loop control, flow/no-flow monitoring, batch operation and feedrate display.

Key Benefits

- Dependable low capacity metering up to 1.68 LPH (0.44 GPH) and pressures up to 10 Bar (150 PSI)
- Reliable metering of fluids even at minimal feed rates
- Flexible automatic signal input - analog or pulse
- Simple user-friendly pump calibration
- Continuous accurate chemical dosing
- Suitable for unmanned installations with auto controls and optional flow monitoring
- Easy to read back-lit digital display of pump capacity, strokes operating mode and alarm
- Low maintenance PVDF head standard
- Corrosion resistant IP65 (NEMA 4X) enclosure
- CE marked electronics

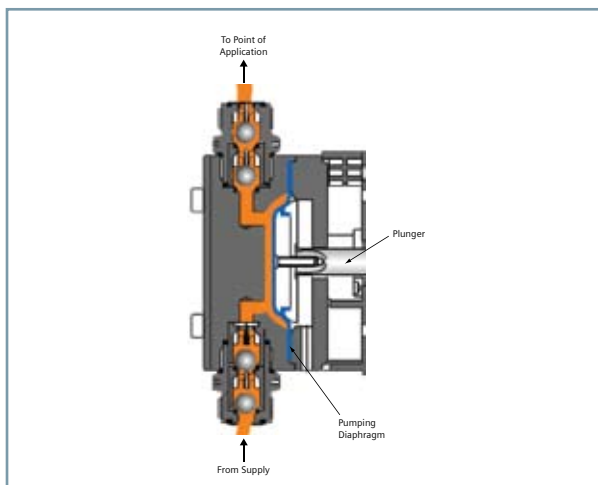

Product Sheet

Description

The Chem-Ad® Series B diaphragm metering pump features integrated automatic analog or pulse controls, and is designed to handle aggressive chemical solutions with flow monitoring capabilities.

Its smooth pulsation characteristics, along with double and triple check valve configuration, ensure high metering accuracy and long life of diaphragms and liquid ends. Due to its unparalleled low noise level and its enclosure, IP 65 (NEMA 4X), the Chem-Ad® Series B pump is perfectly suitable for laboratories and humid ambient conditions.

The basic model has an on/off switch. The standard liquid end made of PVDF ensures a wide range of chemical resistance.

Controls

Manual - E10

Manual control is on-line by means of a mechanical stroke length adjustment via a two-turn knob graduated 0 to 100%. An on/off switch is also provided. There are connections to accept level input and alarm output.

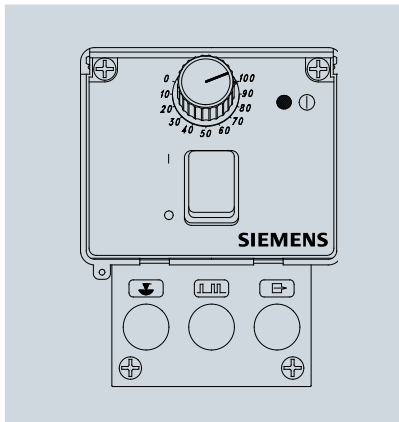

Automatic - E60 (XL Model)

The automatic E60 (XL Model) includes:

- An integrated LED display panel for easy to read, clear indication of operating status and user-friendly programming.
- A four key membrane touch pad simplifies function selection.



- Local or remote control via analog (0/4-20mA or 20-4/0mA) or pulse input signals.
- Signal scaling allows for multiplication or division of the pulse input signal.
- Flow/no flow verification via an optional flow monitor.

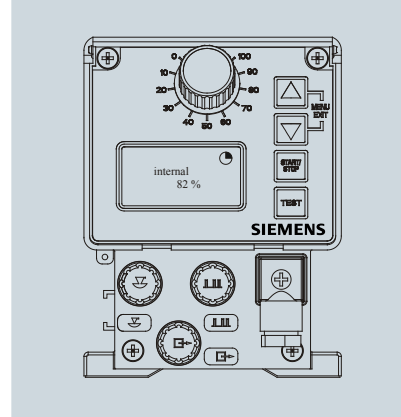

Automatic - E60^{Plus} (XL Model)

With the addition of an intelligent control package (ICP) and Oval Gear Meter (OGM), the E60 becomes the full featured E60^{Plus} and includes:

- Set point controls with automatic frequency compensation for constant chemical feed.
- Chemical consumption data logging.
- Real time feed rate display.
- Plug and play with calibration data storage on OGM.
- Adjustable flow alarm points.

Spares and Accessories

Liquid End PM Kit® Packages

For every model of the Chem-Ad® Series B metering pump, a corresponding maintenance kit is available. This economically priced package contains all spare and wear parts for a prompt and quick maintenance of the liquid end. The Chem-Ad® series of pumps is available with additional useful accessories, three are listed below.

Suction Lance

This option includes pre-wired, built-in-low and empty level switches, foot valve and strainer.



Auto DeGas Valve

An optional auto de-gas valve is available for metering liquids such as sodium hypochlorite, that tend to out-gas at low feed rates and/or during start-stop operation.

Multi-Function Valve

An optional multi-function valve is available for priming, back pressure, pressure relief, and drain.

Selection Guide

To allow easy selection, the Chem-Ad® series of pumps is engineered to the modular design principle. The selection criteria shown to the right provides a perfect guide to define the right pump for the respective duty.

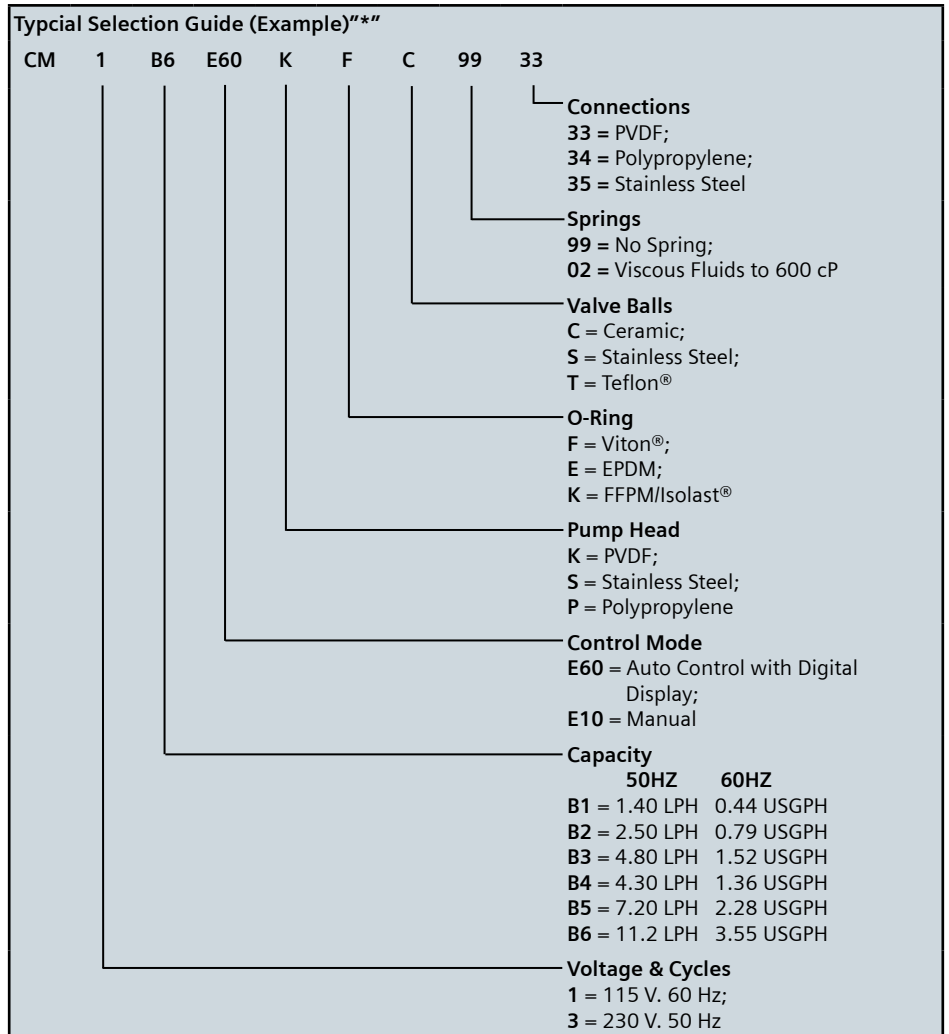

Options / Series B	E10	E60	E60 ^{Plus}
On-Off Button	X	X	X
Manual Stroke Length	X	X	X
Stroke Frequency Control		X	X
Level Input Switch (low level and empty)	X	X	X
Power Cord and Plug	X	X	X
External Analog Input (0-20 or 4-20 mA)		X	X
External Analog Input (0/4-20 mA or 20-4/0 mA)		X	X
Input Signal Scaling		X	X
External Pulse Input		X	X
Remote On / Off		X	X
Batch Mode & Pulse Storage		X	X
Alarm Output & Stroke Pulse Output		X	X
Membrane Touch Pad		X	X
Flow Monitoring (OGM Required)		X	X
Integral Back-Lit Digital Display		X	X
Password Protection		X	X
Capacity Display		X	X
Multiple Language Display (English, German, French)		X	X
Flow Totalizing			X
Set Point Control			X

Note -E60^{Plus} models require ICP & OGM combination.

* This is a typical configuration code, consult factory for product part number

Technical Data

Maximum Capacity LPH / USGPH 60 Hz LPH @ 50 Hz	1.65 / 0.44	3.0 / 0.79	5.76 / 1.52	5.16 / 1.36	8.64 / 2.28	13.44 / 3.55
	1.4	2.5	4.8	4.3	7.2	11.2
Max. Back Pressure (Bar @ 50 Hz / PSI @ 60Hz)	10 / 120		4 / 50	10 / 120		5 / 60
Stroke Frequency Max. (SPM) @ 50/60 Hz	122 / 144					
Capacity / Stroke Max. (cm ³)	0.19	0.34	0.57	0.65	0.98	1.51
Accuracy	Better than \pm 3%					
Max. Suction Lift at 100% *	2 Meters / (6 Ft)					
Suction mm (inches) Connection	4 and 6 mm(3/8" tubing connection)					
Discharge Connection	6, 8,10 or 12 mm tubing (3/8" tubing)					
Power Supply	230 V, 50 Hz / 115 V, 60 Hz (Power Cord and Plug Supplied)					
Current (mA) 115/230 VAC	45 @ 50 Hz / 100 @ 60 Hz			81 @ 50 Hz / 172 @ 60 Hz		130 @ 50 Hz / 300 @ 60 Hz
Max. Power Input (W) 115/230 VAC	10.4			18.7		30
Enclosure	IP65 (NEMA 4X)					
Max. Ambient Temp.	40°C (104°F)					
Insulation Class	B					
Alarm Output Low Level and Tank Empty Contact	Dry contact 24 V, 3 Amps AC/DC or 240 V, 3 Amps AC/DC					
mA Input	0/4-20 mA or 20-4/0 mA (E60 & E60 ^{Plus}) Max. Impedance 50 Ohms					
Pulse Input / Max. Pulse Frequency	Min. pulse length 15msec = 1 stroke; Max. pulse is 122 pulses per minute (@ 50 Hz) / 146 pulses per minute (@ 60 Hz) = continuous running					
Stroke Signal Output	1 Pulse Per Stroke, Dry Contact Rated 24 V DC, 300 mA					
Weight	3.2 Kgs (7 Lbs)					
Dimensions	L 246 mm x W 136 mm x H 147 mm (9 11/16" x 5 5/16" x 5 3/4")					

* Note: Suction lifts with clean, wetted valves. Suction lance with tank level switches is recommended for all capacities. All data refers to water at 20°C (68°F) as per the instruction manual.

Materials of Construction

Pump Head: PVDF (Standard), PP, Stainless Steel

Diaphragm: PTFE Composite

O-Ring: Viton® (Standard), EPDM, Isolast®

Balls: Ceramic (Standard), Stainless Steel, Teflon®

Housing/Finish: Thermoplastic Polyester

Siemens
Water Technologies

Germany
+49 8221 9040
wtger.water@siemens.com

United Kingdom
+44 1732 771777
wtuk.water@siemens.com

USA
+1 856 507 9000
wtus.water@siemens.com

© 2009 Siemens Water Technologies Corp.
Literature No.: WT.440.600.002.IE.PS.0309
Subject to change without prior notice.

Wallace & Tiernan, Chem-Ad, and PM Kit are trademarks of Siemens, its subsidiaries or affiliates. Hastelloy is a trademark of Haynes International, Inc. Isolast is a trademark of Trelleborg AB. NEMA is a trademark of the National Electrical Manufacturers Association. Teflon and Viton are trademarks of Dupont Performance Elastomers LLC.

The information provided in this literature contains merely general descriptions or characteristics of performance which in actual case of use do not always apply as described or which may change as a result of further development of the products. An obligation to provide the respective characteristics shall only exist if expressly agreed in the terms of the contract.