

# Wallace & Tiernan<sup>®</sup> Liquid Chemical Feed Systems Chemtube<sup>®</sup> PPS Model S26 System

The Chemtube<sup>®</sup> PPS Model S26 positive displacement peristaltic pump system is designed to handle a wide variety of chemicals and liquids. Simple operation consists of two rotating rollers that gradually compress as elastomeric tube, forcing liquid just ahead of each roller. The tube snaps back to its original shape after the rollers pass, refilling with liquid for the next discharge revolution. The pumped liquid only comes in contact with the tube interior and the end fittings.

## Features

- Compact footprint
- No seals
- High suction lift capability
- Self priming
- No valves to clog

## Technical Data

**Materials of Construction:**

**Pump Housing:** Cast Iron

**Rotor:** Carbon Steel

**Rollers:** 304 SS

**Mounting Frame:** 304SS

**Available Hose Material:** Natural Isoprene, Buna N, EPDM, Hypalon<sup>®</sup>

**Side Cover:** Acrylic

**Connection & Insert Materials:** 316SS, PVC, or Titanium

**Connection Size:** 1-1/4" NPT

**Leak Detector Switch Rating:** 100 VA Max, 230 Volts, 2.5 amps

**Operating Range:** 20 to 1 with SCR Variable Speed Drive, 10 to 1 or 100 to 1 with Inverter Drive

**Accessories:** Pulsation Dampeners, Calibration Columns, Pressure Relief Valves

**Power Supply:** 115 /230 Volts Single Phase  
230/460 Volts Three Phase

**Fluid Temperature:**

- -10 to 74°C (14 to 165° F) (Buna N Tube )
- -10 to 85°C (14 to 185° F) (Natural Isoprene Tube)
- -10 to 93°C (14 to 200° F) (EPDM Tube)
- -10 to 85°C (14 to 185° F) (Hypalon<sup>®</sup> Tube)

## Key Benefits

- Efficient and smooth, roller technology eliminates the need for an oil bath in the pump housing
- Flexible control options-constant speed, VFD and SCR
- Simplified service and maintenance
- Ideal for multi-phase fluids and slurries
- Early detection of hose failure - leak detector mounted at lowest point of housing
- Unobstructed flow-through pumping

**Max Discharge Pressure:** 8 Bar (120 PSI)

**Max Suction Lift:** 8 m (28 ft.)

**Max Flooded Suction:** 3 Bar (45 PSI)

**Hose Size:** 26mm (ID)

**Motor Hp:** Up to 1-1/2 HP Induction

Up to 1-1/2 HP Inverter or Variable Speed

**Weight:** 66 kgs (145 lbs)

**Shipping Weight:** 73 kgs (160 lbs)



## Product Sheet

S26 Fixed Speed Capacity Chart

RPM	2 Bar (30 PSI)		HP Ind (Inv)	4 Bar (60 PSI)		HP* Ind (Inv)	6 Bar (90 PSI)		HP Ind (Inv)	8 Bar (120 PSI)		HP Ind (Inv)	Duty Cycle
	LPH	GPH		LPH	GPH		LPH	GPH		LPH	GPH		
17.5	435	115	1/2 (3/4)	329	87	1/2 (3/4)	284	75	1/2 (3/4)	246	65	1/2 (3/4)	Continuous
22	529	140	1/2 (3/4)	454	120	1/2 (3/4)	435	115	1/2 (3/4)	341	90	3/4 (3/4)	
27	662	175	1/2 (3/4)	568	150	1/2 (3/4)	454	120	3/4 (3/4)	416	110	3/4 (3/4)	
39	889	235	1/2 (3/4)	814	215	1 (1)	719	190	1 (1)	662	175	1 (1)	Intermittent*
46	1060	280	1/2 (1)	946	250	1 (1)	871	230	1 (1)	833	220	1 (1)	
58	1325	350	1/2 (1)	1211	320	1 (1)	1136	300	1 (1)	X	X	X	
73	1628	430	1/2 (1)	1552	410	1-1/2 (1-1/2)	1438	380	1-1/2 (1-1/2)	X	X	X	
92	2082	550	1 (1)	1968	520	1-1/2 (1-1/2)	1741	460	1-1/2 (1-1/2)	X	X	X	
117	2574	680	1 (1)	2460	650	1-1/2 (1-1/2)	2195	580	1-1/2 (1-1/2)	X	X	X	
140	3104	820	1 (1)	2952	780	1-1/2 (1-1/2)	2668	705	1-1/2 (1-1/2)	X	X	X	

\* Intermittent Duty: Max 1 hour running; Min. 1 hour off

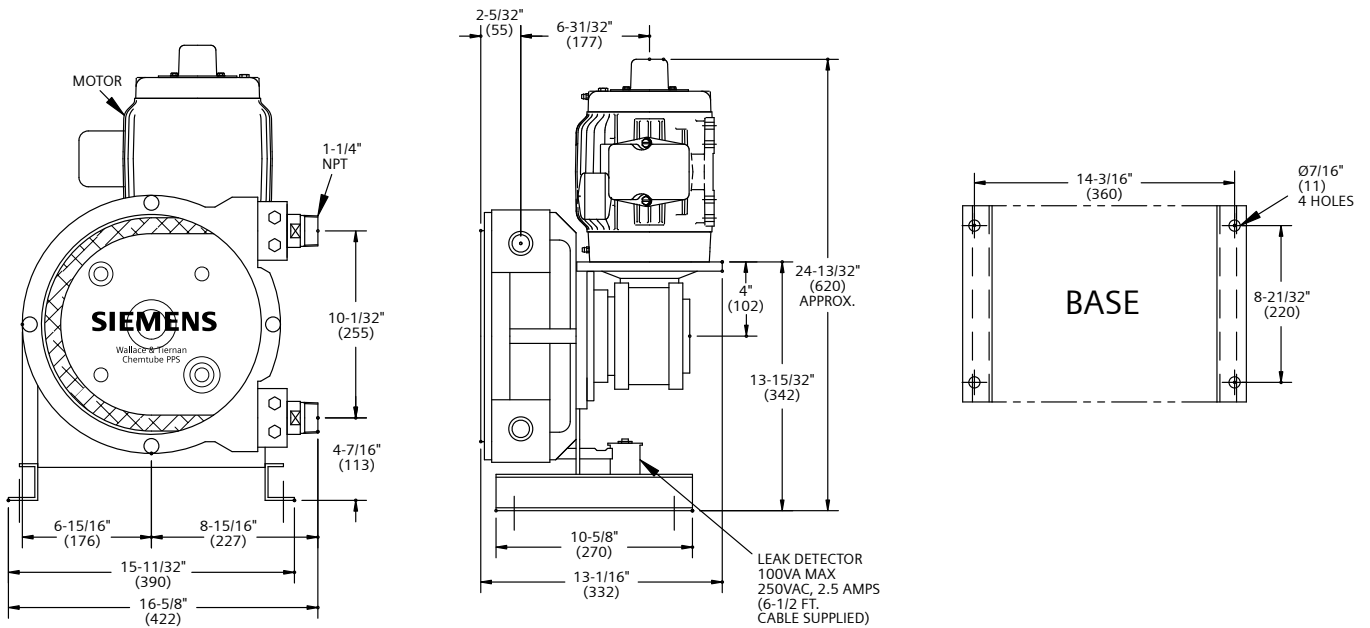

Notes: All dimensions in ( ) are mm. See WT.490.200.110.UA.CN for complete dimensions.

Siemens  
Water Technologies

Germany  
+49 8221 9040  
wtger.water@siemens.com

United Kingdom  
+44 1732 771777  
wtuk.water@siemens.com

USA  
+1 856 507 9000  
wtus.water@siemens.com

© 2008 Siemens Water Technologies Corp.  
Literature No.: WT.490.200.026.IE.PS.1208  
Subject to change without prior notice.

Chemtube and Wallace & Tiernan are trademarks of Siemens, its subsidiaries or affiliates. Hypalon is trademark of DuPont Performance Elastomers LLC.

The information provided in this literature contains merely general descriptions or characteristics of performance which in actual case of use do not always apply as described or which may change as a result of further development of the products. An obligation to provide the respective characteristics shall only exist if expressly agreed in the terms of the contract.