

Wallace & Tiernan® Liquid Chemical Feed Systems Chemtube® PPS Model LD76 System

The Chemtube® PPS Model LD76 positive displacement peristaltic pump system is designed to handle a wide variety of chemicals and liquids. Simple operation consists of two parallel hoses each driven by three rotating rollers that gradually compress the hose, forcing liquid just ahead of each roller. The hose snaps back to its original shape after the rollers pass, refilling with liquid for the next discharge revolution. The pumped liquid only comes in contact with the tube interior and the end fittings.

Features

- Compact footprint
- No seals
- High suction lift capability
- Self priming
- No valves to clog

Technical Data

Materials of Construction:

Pump Housing: Cast Iron
Rotor: Cast Iron
Rollers: Cast Iron
Mounting Frame: Painted Steel
Available Hose Material: Natural Isoprene, Buna N, EPDM, Hypalon®
Side Cover: Polystyrene
Connection & Insert Materials: 316SS, PVC, or Titanium
Connection Size: 3" ANSI 150-lb flange
Leak Detector Switch Rating:
100 VA Max, 230 Volts, 2.5 amps

Operating Range:

20 to 1 with SCR Variable Speed Drive
10 to 1 or 100 to 1 with Inverter Drive

Accessories: Pulsation Dampeners, Calibration Columns, Pressure Relief Valves, Pump Manifold, Wheel Kit

Power Supply: 230/460 Volts Three Phase

Fluid Temperature:

- -10 to 74°C (14 to 165° F) (Buna N Tube)
- -10 to 85°C (14 to 185° F) (Natural Isoprene Tube)
- -10 to 93°C (14 to 200° F) (EPDM Tube)
- -10 to 85°C (14 to 185° F) (Hypalon® Tube)

Key Benefits

- Efficient and smooth, roller technology eliminates the need for an oil bath in the pump housing
- Flexible control options-constant speed, VFD and SCR
- Simplified service and maintenance
- Ideal for multi-phase fluids and slurries
- Early detection of hose failure - leak detector mounted at lowest point of housing
- Unobstructed flow-through pumping

Max Discharge Pressure: 15 Bar (225 PSI)

Max Suction Lift: 8 m (28 ft)

Max Flooded Suction: 23 PSI

Hose Size: 76mm (ID)

Motor Hp:

Up to 20 HP Induction

Up to 20 HP Inverter or Variable Speed

Weight: 770 kgs (1700 lbs)

Shipping Weight: 815 kgs (1800 lbs.)

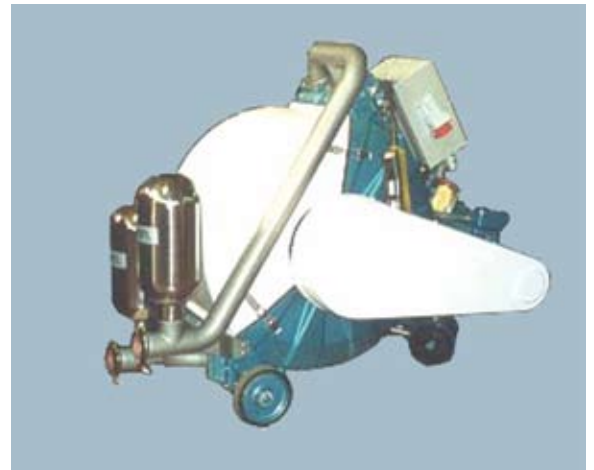

Product Sheet

LD76 Fixed Speed Capacity Chart										
RPM	2 Bar (30 PSI)		HP*	3 Bar (45 PSI)		HP*	3.3 Bar (50PSI)		HP*	Duty Cycle
	LPH	GPH	Ind & Inv	LPH	GPH	Ind & Inv	LPH	GPH	Ind & Inv	
21	25738	6800	15	24980	6600	15	24220	6400	15	Continuous
33	41256	10900	15	39743	10500	15	38607	10200	15	Intermittent*
47	58290	15400	15	X	X	X	X	X	X	
RPM	3.3 Bar (50 PSI)		HP*	6.7 Bar (100 PSI)		HP*	15 Bar (225 PSI)		HP*	Duty Cycle
	LPH	GPH	Ind & Inv	LPH	GPH	Ind & Inv	LPH	GPH	Ind & Inv	
20	20440	5400	20	18900	5000	20	17000	4500	20	Continuous
32	32550	8600	20	28380	7500	20	X	X	X	Intermittent*
45	41630	11000	20	X	X	X	X	X	X	

Note: Shaded areas denote intermittent service.

*Intermittent Duty: Max. 1 hour running; Min. 1 hour off.

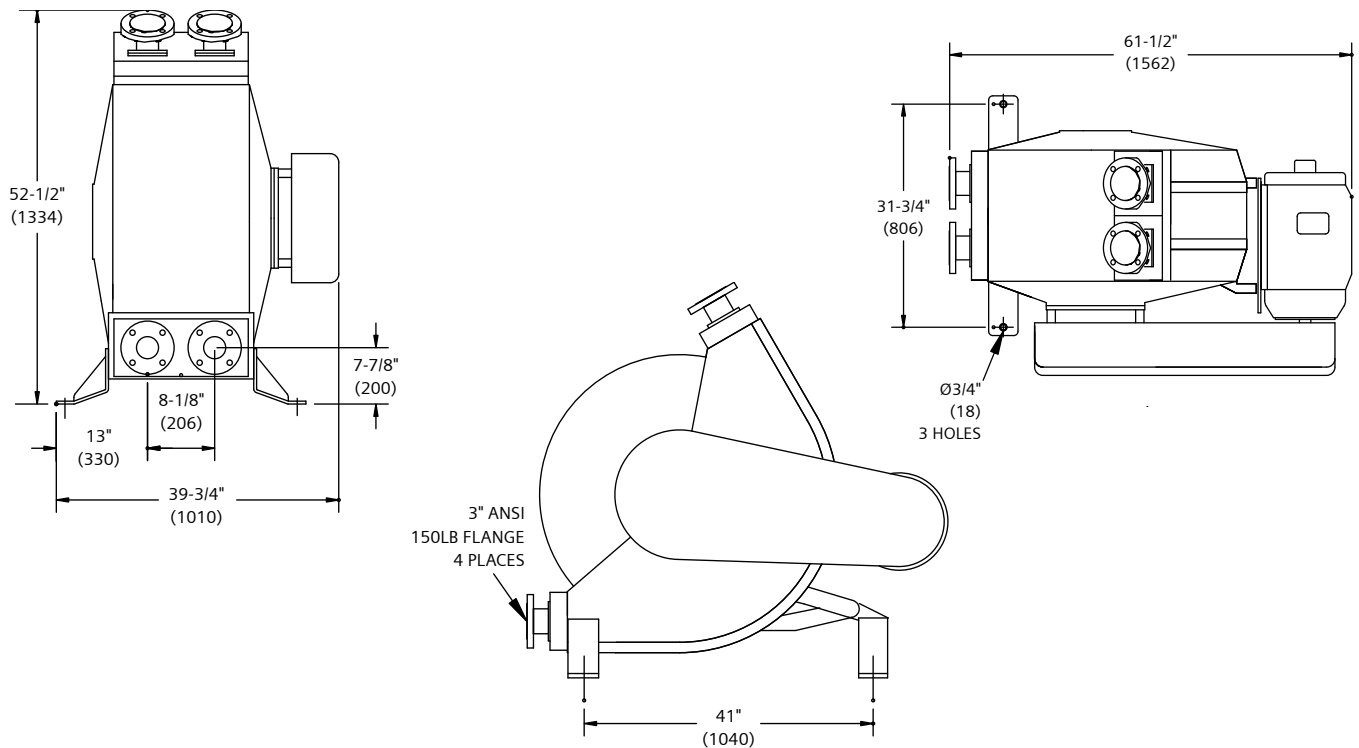

Notes: All dimensions in () are mm. See WT.490.200.138.UA.CN and WT.490.200.140.UA.CN for complete dimensions.

Siemens
Water Technologies

Germany
+49 8221 9040
wtger.water@siemens.com

United Kingdom
+44 1732 771777
wtuk.water@siemens.com

USA
+1 856 507 9000
wtus.water@siemens.com

© 2008 Siemens Water Technologies Corp.
Literature No.: WT.490.200.D76.IE.PS.1208
Subject to change without prior notice.

Chemtube and Wallace & Tiernan are trademarks of Siemens, its subsidiaries or affiliates. Hypalon is trademark of DuPont Performance Elastomers LLC.

The information provided in this literature contains merely general descriptions or characteristics of performance which in actual case of use do not always apply as described or which may change as a result of further development of the products. An obligation to provide the respective characteristics shall only exist if expressly agreed in the terms of the contract.